



# **USER'S GUIDE**

## **ServeRAID M5014/M5015 SAS/SATA Controllers**

**September 2009**

**First Edition (September 2009)**

© Copyright International Business Machines Corporation 2009. All rights reserved.

US Government Users Restricted Rights – Use, duplication or disclosure  
restricted by GSA ADP Schedule Contract with IBM Corp.

# Preface

---

This book is the primary reference and user's guide for the ServeRAID M5014 SAS/SATA controller and the ServeRAID M5015 SAS/SATA controller. It contains installation instructions and specifications for the adapter, and it explains how to install and use the ServeRAID M5000 Series Battery Assembly with the ServeRAID M5014 and M5015 SAS/SATA controllers. In addition, it explains how to install the ServeRAID M5000 Series Advanced Feature Key on the ServeRAID M5015 SAS/SATA controller.

For details on how to configure the storage adapter, refer to the *ServeRAID-M Software User's Guide*. For information about the operating system drivers, refer to the *ServeRAID-M Device Driver Installation User's Guide*.

---

## Audience

This document assumes that the reader is familiar with RAID controllers and related support devices. The people who benefit from this book are:

- Engineers who are designing a system that will include a ServeRAID M5014 or a ServeRAID M5015 SAS/SATA controller
- Anyone installing a ServeRAID M5014 or ServeRAID M5015 SAS/SATA controller in a RAID system
- End users who need to install a ServeRAID M5000 Series Battery Assembly product on a ServeRAID M5014 SAS/SATA controller

**Note:** The ServeRAID M5000 Series Battery Assembly is pre-installed on the ServeRAID M5015 SAS/SATA controller.

- End users who need to install a ServeRAID M5000 Series Advanced Feature Key on a ServeRAID M5015 SAS/SATA controller.

- Engineers and managers who are evaluating battery-protected backup products for cached memory for possible use with ServeRAID-M controllers

---

## Organization

This document has the following chapters and appendices:

- **Chapter 1, Overview**, provides a general overview of the ServeRAID M5014 and ServeRAID M5015 SAS/SATA controllers.
- **Chapter 2, ServeRAID Controller Hardware Installation**, describes the procedures for installing the ServeRAID M5014 and ServeRAID M5015 SAS/SATA controllers.
- **Chapter 3, ServeRAID M5014/M5015 SAS/SATA Controller Characteristics**, provides the characteristics and technical specifications for the ServeRAID M5014 and ServeRAID M5015 SAS/SATA controllers.
- **Chapter 4, Intro to the ServeRAID M5000 Series Battery Assembly**, describes the ServeRAID M5000 Series Battery Assembly and explains how it operates.
- **Chapter 5, Installing a ServeRAID M5000 Series Battery Assembly**, explains how to install the ServeRAID M5000 Series Battery Assembly on the ServeRAID M5014 SAS/SATA controller.
- **Chapter 6, Using the ServeRAID M5000 Series Battery Assembly**, explains how to use and monitor the ServeRAID M5000 Series Battery Assembly, and how to replace it.
- **Chapter 7, ServeRAID M5000 Series Battery Assembly Specifications**, has complete technical information and specifications for the ServeRAID M5000 Series Battery Assembly.
- **Chapter 8, Installing a ServeRAID M5000 Series Advanced Feature Key**, describes how to install the ServeRAID M5000 Series Advanced Feature Key.
- **Appendix A, Notices**, contains information about the warranty, patents, license inquiries, and trademarks.
- **Appendix B, Glossary of Terms and Abbreviations**, lists and explains the terms and abbreviations used in this manual.

---

## Related Publications

### **ServeRAID-M Device Driver Installation User's Guide**

*IBM Document Number: 46M1382*

This document explains how to install the ServeRAID-M device driver for your operating system. The information in this document is independent of the back-end bus and applies to the ServeRAID-M controllers.

### **ServeRAID-M Software User's Guide**

*IBM Document Number: 46M1381*

This document explains how to use the MegaRAID Storage Manager, WebBIOS, and Command Line Interface (CLI) utilities to configure, monitor, and maintain the ServeRAID-M controller and the storage-related devices connected to them.

### **IBM Systems Safety Notices**

*IBM Document Number: G229-9054-01*

This book contains safety notices from IBM Systems documentation. The safety notices include danger and caution notices.

---

## Notices and Statements in This Document

The caution and danger statements in this document are also in the multilingual *IBM Systems Safety Notices* document, which is on the *ServeRAID-M Support* CD. Each statement is followed by a reference number that you can use to locate the corresponding statement in your language in the IBM Systems Safety Notices document. The following notices and statements are used in this document:

**Note:** These notices provide important tips, guidance, or advice.

**Important:** These notices provide information or advice that might help you avoid inconvenient or problem situations.

**Attention:** These notices indicate potential damage to programs, devices, or data. An attention notice is placed just before the instruction or situation in which damage might occur.

**CAUTION:** These statements indicate situations that can be potentially hazardous to you. A caution statement is placed just before the description of a potentially hazardous procedure step or situation.

**DANGER:** These statements indicate situations that can be potentially lethal or extremely hazardous to you. A danger statement is placed just before the description of a potentially lethal or extremely hazardous procedure step or situation.

---

## Revision History

Edition/Date	Remarks
First Edition September 2009	Initial release of document.

---

## IBM Customer Support

**Web site:** <http://www.ibm.com/systems/support/>

**Note:** Record your controller serial number in a safe location in case you need to contact IBM.

---

## Safety Instructions

Use the following safety guidelines to help protect your computer system from potential damage and to ensure your own personal safety.

**Note:** Use your ServeRAID M5014 or ServeRAID M5015 SAS/SATA controller with UL-listed Information Technology Equipment (ITE) products only.



### **DANGER**

When working on or around the system, observe the following precautions:

Electrical voltage and current from power, telephone, and communication cables are hazardous. To avoid a shock hazard:

- Connect power to this unit only with the provided power cord. Do not use the provided power cord for any other product.
- Do not open or service any power supply assembly.
- Do not connect or disconnect any cables or perform installation, maintenance, or reconfiguration of this product during an electrical storm.
- The product might be equipped with multiple power cords. To remove all hazardous voltages, disconnect all power cords.
- Connect all power cords to a properly wired and grounded electrical outlet. Ensure that the outlet supplies proper voltage and phase rotation according to the system rating plate.
- Connect any equipment that will be attached to this product to properly wired outlets.
- When possible, use one hand only to connect or disconnect signal cables.
- Never turn on any equipment when there is evidence of fire, water, or structural damage.
- Disconnect the attached power cords, telecommunications systems, networks, and modems before you open the device covers, unless instructed otherwise in the installation and configuration procedures.
- Connect and disconnect cables as described in the following procedures when installing, moving, or opening covers on this product or attached devices.

To disconnect:

1. Turn off everything (unless instructed otherwise).
2. Remove the power cords from the outlets.
3. Remove the signal cables from the connectors.
4. Remove all cables from the devices.

To connect:

1. Turn off everything (unless instructed otherwise).
2. Attach all cables to the devices.
3. Attach the signal cables to the connectors.
4. Attach the power cords to the outlets.
5. Turn on the devices.

(D005)



**CAUTION:**

The battery is a lithium ion battery and can present a fire or chemical burn hazard if mistreated. Do not disassemble, heat above 100 °C (212 °F), or incinerate. To avoid possible explosion, do not burn. Keep away from children. Exchange only with the IBM-approved part. Recycle or discard the battery as instructed by local regulations. In the United States, IBM has a process for the collection of this battery. For information, call 1-800-426-4333. Have the IBM part number for the battery unit available when you call. (C007)

**Protecting against Electrostatic Discharge** – Static electricity can harm delicate components inside your computer. To prevent static damage, discharge static electricity from your body before you touch any of your computer’s electronic components, such as the microprocessor. You can do so by touching an unpainted metal surface, such as the metal around the card-slot openings at the back of the computer.

As you continue to work inside the computer, periodically touch an unpainted metal surface to remove any static charge your body may have accumulated. In addition to the preceding precautions, you can also take the following steps to prevent damage from electrostatic discharge:

- When unpacking a static-sensitive component from its shipping carton, do not remove the component from the antistatic packing material until you are ready to install the component in your computer. Just before unwrapping the antistatic packaging, be sure to discharge static electricity from your body.
- When transporting a sensitive component, first place it in an antistatic container or packaging.
- Handle all sensitive components in a static-safe area. If possible, use antistatic floor pads and workbench pads.



# Contents

---

## Chapter 1 Overview

1.1	Overview	1-1
1.2	ServeRAID M5014/M5015 Controllers Descriptions and Limitations	1-3
1.2.1	Controller Limitations	1-3
1.3	General Description	1-4
1.4	Configuration Scenarios	1-5
1.4.1	Number of Physical Disks Supported	1-7
1.5	Benefits of the SAS Interface	1-8
1.5.1	PCI Express Architecture	1-8
1.5.2	Operating System Support	1-9
1.6	Benefits of the ServeRAID M5014 and ServeRAID M5015 Controllers	1-9
1.6.1	SAS Features	1-10
1.6.2	SAS Array Limitations	1-10
1.6.3	SATA II Features	1-11
1.6.4	PCI Express Performance	1-12
1.6.5	Usability Features	1-12
1.6.6	Flexibility Features	1-13
1.6.7	Drive Roaming	1-13
1.6.8	Drive Migration	1-14
1.7	Hardware Specifications	1-15
1.8	Technical Support	1-16

---

## Chapter 2 ServeRAID Controller Hardware Installation

2.1	Requirements	2-1
2.2	Quick Installation	2-2

2.3	Detailed Installation	2-2
2.4	SAS Device Cables	2-6
2.4.1	Connecting the ServeRAID M5014 or ServeRAID M5015 SAS/SATA Controller to Physical Drives	2-8
2.5	After Installing the Controller	2-10
2.6	Replacing a Failed Controller Containing Data in the Battery Backup Unit	2-10

---

## Chapter 3

### ServeRAID M5014/M5015 SAS/SATA Controller Characteristics

3.1	ServeRAID M5014/M5015 SAS/SATA Controller Descriptions	3-1
3.1.1	Board Layout and Connector Information	3-1
3.2	Characteristics of the ServeRAID M5014/M5015 Controllers	3-4
3.3	Technical Specifications	3-4
3.3.1	Controller Specifications	3-5
3.3.2	Array Performance Features	3-6
3.3.3	Fault Tolerance	3-6
3.3.4	Power Supply Requirements for the ServeRAID M5014/M5015 Controllers	3-7
3.3.5	Operating and Non-operating Conditions	3-8
3.3.6	Safety Characteristics	3-8

---

## Chapter 4

### Intro to the ServeRAID M5000 Series Battery Assembly

## Chapter 5

### Installing a ServeRAID M5000 Series Battery Assembly

5.1	Installing the ServerRAID M5000 Series Battery Assembly on a Controller	5-2
-----	---	-----

---

## Chapter 6

### Using the ServeRAID M5000 Series Battery Assembly

6.1	Monitoring the Battery Backup with the MegaRAID Configuration Utilities	6-2
6.1.1	Monitoring the ServeRAID M5000 Series Battery Assembly with the WebBIOS Configuration Utility	6-2
	<b>Setting the Learn Delay Interval</b>	<b>6-5</b>

	<b>Setting the Learn Mode</b>	<b>6-5</b>
6.1.2	Monitoring the ServeRAID M5000 Series Battery Assembly with the MegaCLI Utility	6-5
	Display BBU Information	6-5
	Display BBU Status Information	6-6
	Display BBU Capacity	6-7
	Display BBU Design Parameters	6-7
	Display Current BBU Properties	6-7
	Start BBU Learning Cycle	6-8
	Place Battery in Low-Power Storage Mode	6-8
	Set BBU Properties	6-8
6.1.3	Monitoring the Battery Backup with MegaRAID Storage Manager	6-9
	Battery Learn Cycle	6-10
	Setting the Learn Cycle Properties	6-11
	Starting a Learn Cycle Manually	6-12
6.2	Replacing the ServeRAID M5000 Series Battery Assembly	6-12
6.3	Transferring Cached Data from a Failed Controller	6-13
6.4	Resolving a Configuration Mismatch	6-14

---

## Chapter 7

### ServeRAID M5000 Series Battery Assembly Specifications

7.1	Intelligent Battery Backup Unit Specifications	7-1
7.2	Battery Life and Data Retention Time	7-2

---

## Chapter 8

### Installing a ServeRAID M5000 Series Advanced Feature Key

8.1	Installing the ServeRAID M5000 Series Advanced Feature Key on the ServeRAID M5015 SAS/SATA Controller	8-1
-----	---	-----

---

## Appendix A

### Notices

A.1	Trademarks	A-2
A.2	Important Notes	A-3

---

## Appendix B

### Glossary of Terms and Abbreviations



---

## Figures

1.1	Example of a SAS Direct-Connect Application	1-6
1.2	Example of a ServeRAID Controller Configured with an LSISASx12 Expander	1-7
2.1	ServeRAID M5014/M5015 Controllers Installation in a PCI Express Slot	2-4
2.2	Internal SAS Cable for Connection to SAS Physical Drives or SATA II Physical Drives	2-7
2.3	SATA II Connectors	2-7
2.4	SAS Plugs, SATA II Plugs, and SAS Backplane Receptacle Connector	2-8
2.5	Connecting the ServeRAID M5014/M5015 Controller Internal Connectors to a Physical Drive	2-9
3.1	Card Layout for the ServeRAID M5014/M5015 RAID Controllers	3-2
5.1	ServeRAID M5000 Series Battery Assembly	5-2
5.2	Installing the ServeRAID M5000 Series Battery Assembly on the ServeRAID M5014 Controller	5-4
5.3	Installing the ServeRAID M5014 Controller	5-5
6.1	First Controller Properties Screen	6-3
6.2	Second Controller Properties Screen	6-3
6.3	Battery Module Screen	6-4
8.1	M5000 Series Advanced Feature Key	8-1
8.2	Installing the ServeRAID M5000 Series Advanced Feature Key on the M5015 ServeRAID SAS/SATA Controller	8-2



---

## Tables

1.1	Physical Devices Required for Each RAID Level	1-7
1.2	ServeRAID M5014/M5015 SAS/SATA Controller Array Limitations	1-11
1.3	ServeRAID M5014/M5015 SAS/SATA Controller Specifications	1-16
3.1	ServeRAID M5014 and ServeRAID M5015 Controllers Connectors	3-2
3.2	ServeRAID M5014 and ServeRAID M5015 SAS/SATA Controllers Characteristics	3-4
3.3	ServeRAID M5014 and ServeRAID M5015 SAS/SATA Controllers Specifications	3-5
3.4	Array Performance Features	3-6
3.5	Fault Tolerance Features	3-7
3.6	Power Supply for the ServeRAID M5014/M5015 Controllers	3-8
6.1	Display BBU Information	6-5
6.2	Display BBU Status Information	6-6
6.3	Display BBU Capacity Information	6-7
6.4	Display BBU Design Parameters	6-7
6.5	Display Current BBU Properties	6-8
6.6	Start BBU Learning Cycle	6-8
6.7	Place Battery in Low-Power Storage Mode	6-8
6.8	Set BBU Properties	6-8
7.1	ServeRAID M5000 Series Battery Assembly Specifications	7-2
7.2	Reference Data Retention Times	7-3





# Chapter 1

## Overview

---

This section provides a general overview of the ServeRAID M5014 SAS/SATA controller and the ServeRAID M5015 SAS/SATA controller, which have RAID control capabilities. It consists of the following sections:

- [Section 1.1, “Overview”](#)
  - [Section 1.2, “ServeRAID M5014/M5015 Controllers Descriptions and Limitations”](#)
  - [Section 1.3, “General Description”](#)
  - [Section 1.4, “Configuration Scenarios”](#)
  - [Section 1.5, “Benefits of the SAS Interface”](#)
  - [Section 1.6, “Benefits of the ServeRAID M5014 and ServeRAID M5015 Controllers”](#)
  - [Section 1.7, “Hardware Specifications”](#)
  - [Section 1.8, “Technical Support”](#)
- 

### 1.1 Overview

The ServeRAID M5014 and M5015 Serial Attached SCSI (SAS)/Serial ATA II (SATA II) controllers are high-performance intelligent PCI Express-to-SAS/SATA II adapters with RAID control capabilities. These controllers provide reliability, high performance, and fault-tolerant disk subsystem management. They are an ideal RAID solution for the storage of workgroup, departmental, and enterprise systems. The controllers offer a cost-effective way to implement RAID in a server.

SAS technology brings a wealth of options and flexibility with the use of SAS devices and SATA II devices within the same storage infrastructure. However, SAS devices and SATA devices bring individual characteristics that make each one a more suitable choice depending on your storage

needs. MegaRAID® gives you the flexibility to combine these two similar technologies on the same controller and within the same enclosure.

**Note:** You cannot mix SAS drives and SATA drives within the same *virtual disk(s)*.

The ServeRAID M5014 and ServeRAID M5015 controllers are based on the MegaRAID first-to-market SAS IC technology and proven technology. As the second-generation PCI Express controllers, they address the growing demand for increased data throughput and scalability requirements across midrange and enterprise-class server platforms. IBM offers a family of SAS controllers to address the needs for both internal solutions and external solutions.

The ServeRAID M5000 Series Battery Assembly is pre-installed on the ServeRAID M5015 controller to provide battery-protected backup of cached memory. The assembly provides protection of cached data, which allows system builders to protect cached data even during the most catastrophic system failures.

**Note:** The ServeRAID M5000 Series Battery Assembly is not pre-installed on the ServeRAID M5014 controller but you can install it. See [Section 5.1, “Installing the ServerRAID M5000 Series Battery Assembly on a Controller”](#) for installation instructions.

**Note:** You must charge the battery before use. See [Chapter 4, “Intro to the ServeRAID M5000 Series Battery Assembly,”](#) for more information about the battery backup unit.

The ServeRAID M5000 Series Advanced Feature Key enables support for RAID 6 configurations and self-encrypting disks (SED) on the ServeRAID M5015 SAS/SATA controller. The ServeRAID M5000 Series Advanced Feature Key mounts directly on the controller. See [Chapter 8, “Installing a ServeRAID M5000 Series Advanced Feature Key”](#) for installation instructions.

The controller supports the SAS protocol as described in the *Serial Attached SCSI Standard, version 2.0*. It also supports the Serial ATA II (SATA II) protocol defined by the *Serial ATA Specification, Version 1.0a*, and the *Serial ATA II; Extension to the Serial ATA Specification, Version 1.1*. SATA II is an extension to SATA 1.0a. The ServeRAID 5014 and

ServeRAID M5015 controllers are versatile controllers that provide the backbone of both server and high-end workstation environments.

Each port on the controllers supports SAS devices and/or SATA II devices using the following:

- SAS Serial SCSI Protocol (SSP), which enables communication with other SAS devices
- SATA II, which enables communication with other SATA II devices
- Serial Management Protocol (SMP), which communicates topology management information directly with an attached SAS expander device
- Serial Tunneling Protocol (STP), which enables communication with a SATA II device through an attached expander

---

## 1.2 ServeRAID M5014/M5015 Controllers Descriptions and Limitations

The ServeRAID M5014 and ServeRAID M5015 controllers are available with eight PHYs. The controllers have one LSISAS2108 ROC (RAID-on-chip) processor that controls eight internal SAS/SATA ports through two x4 SAS internal connectors.

### 1.2.1 Controller Limitations

The ServeRAID M5014 and ServeRAID M5015 controllers have the following limitations:

- You can connect only one device per SAS PHY unless you use an expander
- You can use a maximum cable length of six feet (using shorter cables is preferred)
- Cables have to meet the SAS specification
- You cannot mix SAS drives and SATA drives in the same virtual disk
- You cannot mix SAS or SATA Solid State Drives (SSDs) and legacy mechanical drives (SAS or SATA) in the same virtual disk

- You cannot mix Solid State SAS drives and Solid State SATA drives in the same virtual disk
- See [Section 3.3.4, “Power Supply Requirements for the ServeRAID M5014/M5015 Controllers,”](#) for information about the power requirements, and [Section 3.3.5, “Operating and Non-operating Conditions”](#) for information about the minimum and maximum temperature ranges.

---

## 1.3 General Description

The ServeRAID M5014 and ServeRAID M5015 controllers bring 6.0 Gb/s Serial Attached SCSI and 3.0 Gb/s Serial ATA II performance to host adapter, workstation, and server designs. The controllers support internal storage devices, which allows you to use a system that supports enterprise-class SAS drives, and desktop-class SATA II drives. Both controllers can connect to drives directly. Simplified cabling between devices is an additional benefit.

The controllers are based on the LSISAS2108 ROC device. This device is compliant with the Fusion-MPT architecture and provides a PCI Express x8 interface.

The controllers integrate eight high-performance SAS/SATA II PHYs and a PCI Express bus master DMA core. Each of the eight PHYs is capable of 6.0 Gb/s SAS link rates and 3.0 Gb/s SATA II link rates.

The LSISAS2108 ROC device provides an eight-lane, 5-Gb/s PCI Express host interface, eight 6.0 Gb/s SAS or 3.0 Gb/s SATA ports, and a full-featured, hardware-based RAID implementation. The LSISAS2108 ROC device integrates a high-speed DDR/DDR2 SDRAM interface with a hardware RAID assist engine for parity calculations. The LSISAS2108 ROC device provides the maximum benefits of a RAID system and enables you to configure the system to satisfy your system requirements.

The LSISAS2108 ROC device increases system performance and provides fault-tolerant data storage. The LSISAS2108 supports data striping across multiple disks, which reduces disk access time because multiple disks simultaneously read or write data. The LSISAS2108 ROC device backs up data with either data mirroring or a parity block. Either backup method enables you to recover lost data in the event of a disk

failure. You can select the data backup method that best suits your needs. A hardware RAID assist exclusive-OR (XOR) engine speeds parity generation and checking and reduces system-access times.

The controller supports the SAS protocol as described in the *Serial Attached SCSI Standard, version 2.0*. In addition, it supports the Serial ATA II (SATA II) protocol defined by the *Serial ATA Specification, Version 1.0a*, and the *Serial ATA II; Extension to the Serial ATA Specification, Version 1.1*. SATA II is an extension to SATA 1.0a. The controller supports the following SATA II features:

- 3 Gb/s SATA II
- Staggered spin-up
- Hot plug
- Native command queuing
- Activity and fault indicators for each PHY
- Port Selector (for dual-port drives)

Each port on the ServeRAID M5015 controller supports SAS devices, SATA II devices, or both using SSP, SMP, STP, and SATA II. SSP enables communication with other SAS devices. SATA II enables the controller to communicate with other SATA II devices.

---

## 1.4 Configuration Scenarios

There are two main scenarios in which you can use these ServeRAID controllers:

- **Low-end, internal SATA II configuration:** In this configuration, use the ServeRAID controller as a high-end SATA II compatible controller that connects up to eight disks. This configuration is mostly for low-end or entry servers. Enclosure management is provided through out-of-band I<sup>2</sup>C bus. Side bands of both types of internal SAS connectors support the SFF-8485 (SGPIO) interface.
- **Midrange, internal SAS configuration:** This is like the internal SATA II configuration, but with high-end disks. This is more suitable for low-range to midrange servers.

Figure 1.1 shows a direct-connect configuration. The Inter-IC (I<sup>2</sup>C) interface communicates with peripherals. The external memory bus provides a 32-bit memory bus, parity checking, and chip select signals for pipelined synchronous burst static random access memory (PSBRAM), nonvolatile static random access memory (NVSRAM), and Flash ROM.

**Figure 1.1 Example of a SAS Direct-Connect Application**

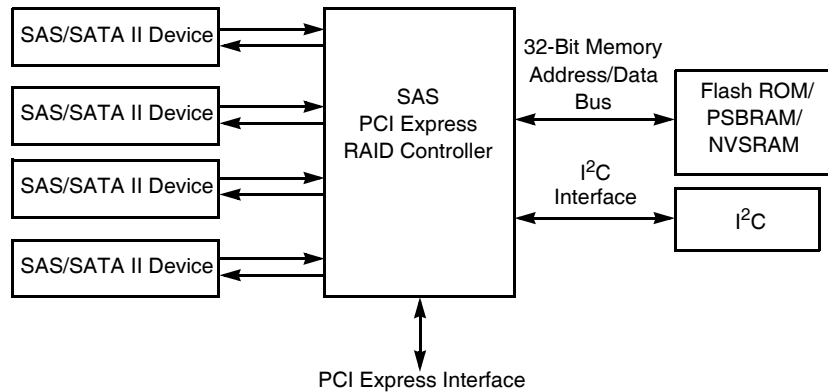
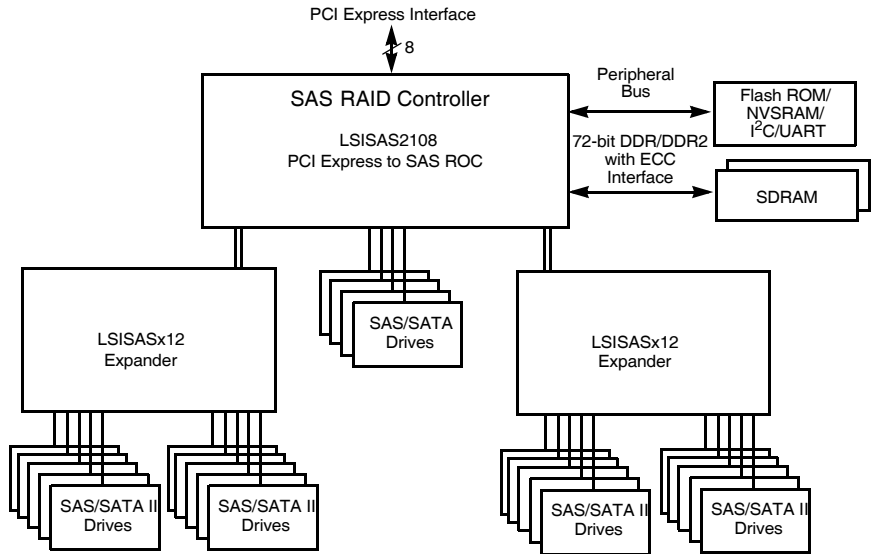

Figure 1.2 shows an example of a ServeRAID controller configured with an LSI SASx12 expander that is connected to SAS disks, SATA II disks, or both.

**Figure 1.2 Example of a ServeRAID Controller Configured with an LSISASx12 Expander**



### 1.4.1 Number of Physical Disks Supported

Your configuration planning for your ServeRAID controller depends in part on the number of physical disks that you want to use in a RAID array. The number of drives in an array determines the RAID levels that can be supported by this controller. Only one RAID level can be assigned to each virtual disk. [Table 1.1](#) shows the minimum number and the maximum number of drives required for each RAID level.

**Table 1.1 Physical Devices Required for Each RAID Level**

RAID Level	Minimum # of Physical Devices	Maximum # of Physical Devices
0	1	16
1	2	2
5	3	16
10	4	16
50	6	16

---

## 1.5 Benefits of the SAS Interface

SAS is a serial, point-to-point, enterprise-level device interface that leverages the proven SCSI protocol set. SAS combines the advantages of SATA II, SCSI, and Fibre Channel, and is the future mainstay of the enterprise and high-end workstation storage markets. SAS offers a higher bandwidth per pin than parallel SCSI, and it improves signal and data integrity.

The SAS interface uses the proven SCSI command set to ensure reliable data transfers, while providing the connectivity and flexibility of point-to-point serial data transfers. The serial transmission of SCSI commands eliminates clock-skew challenges. The SAS interface provides improved performance, simplified cabling, smaller connectors, lower pin count, and lower power requirements when compared to parallel SCSI.

The ServeRAID M5014 and ServeRAID M5015 controllers leverage a common electrical and physical connection interface that is compatible with Serial ATA technology. The SAS protocols and SATA II protocols use a thin, 7-wire connector instead of the 68-wire SCSI cable or 26-wire ATA cable. The SAS/SATA II connector and cable are easier to manipulate, allow connections to smaller devices, and do not inhibit airflow. The point-to-point SATA II architecture eliminates inherent difficulties created by the legacy ATA master-slave architecture, while maintaining compatibility with existing ATA firmware.

### 1.5.1 PCI Express Architecture

PCI Express is a local bus system designed to increase data transfers without slowing down the central processing unit (CPU). You can install your ServeRAID M5014 or ServeRAID M5015 PCI Express SAS/SATA controllers in PCI Express computer systems with a standard bracket type. With these adapters in your system, you can connect SCSI devices and SATA II devices over the bus.

PCI Express goes beyond the PCI specification in that it is intended as a unifying I/O architecture for various systems: desktops, workstations, mobile, server, communications, and embedded devices.



## 1.5.2 Operating System Support

To check for the latest list of supported operating systems and to download the drivers for those operating systems, see <http://www.ibm.com/systems/support/>.

The ServeRAID M5014 and ServeRAID M5015 controllers use Fusion-MPT™ architecture for all major operating systems, thinner drivers, and better performance.

---

## 1.6 Benefits of the ServeRAID M5014 and ServeRAID M5015 Controllers

This section provides a summary of the features and benefits of the ServeRAID M5014 and ServeRAID M5015 controllers. It contains information on SAS features, SATA II features, PCI performance, integration, usability, and flexibility.

The ServeRAID M5014 and ServeRAID M5015 controllers offer the following features:

- PCI Express x8 lane width
- PCI Express performance up to 5 Gb/s per lane
- **ServeRAID M5014 controller** - Support for 256-Mbyte 40-bit DDR2 800 MHz on-board SDRAM intelligent battery backed module
- **ServeRAID M5015 controller** - Support for 512-Mbyte 72-bit DDR2 800 MHz on-board SDRAM intelligent battery backed module
- Two internal connectors
- Support for RAID levels 0, 1, 5, 10, and 50
- Advanced array configuration and management utilities
- Online RAID level migration
- Drive migration
- Drive roaming
- Media scan
- No reboot necessary after expansion

- More than 200 Qtags per array
- User-specified rebuild rate
- 32-Kbyte nonvolatile random access memory (NVRAM) for storing RAID system configuration information; the MegaRAID SAS firmware is stored in flash ROM for easy upgrade.

## 1.6.1 SAS Features

The following list describes the SAS features of the ServeRAID M5014 and ServeRAID M5015 controllers:

- Provides eight fully independent PHYs
- Supports 6.0 Gb/s SAS data transfers per PHY
- Supports SSP to enable communication with other SAS devices
- Supports SMP to communicate topology management information
- Provides a serial, point-to-point, enterprise-level storage interface
- Simplifies cabling between devices
- Provides a scalable interface that supports up to 240 devices through the use of expanders
- Supports wide ports consisting of 2, 3, or 4 PHYs within a single quad port
- Supports narrow ports consisting of a single PHY
- Transfers data using SCSI information units

## 1.6.2 SAS Array Limitations

This section describes the array limitations of the controllers. These include limitations such as the number of physical disks supported, the maximum number of disks per controller, and the maximum number of virtual disks allowed per controller.

[Table 1.2](#) lists the array limitations for the ServeRAID M5014 and ServeRAID M5015 controllers.

**Table 1.2    ServeRAID M5014/M5015 SAS/SATA Controller Array Limitations**

<b>Specification</b>	<b>ServeRAID M5014/M5015 SAS/SATA Controllers</b>
Maximum virtual disks per controller	32
Maximum arrays per controller	16
Maximum virtual disks per array	16
Maximum physical devices per array	16
Maximum physical devices per controller	16
Maximum hot spares	16
Maximum spans per virtual disk	8
Maximum ports	2

**Note:**    The maximum number of hot spares per array is equal to the maximum number of physical drives per array.

The controller supports 64-bit logical block addressing (LBA), which makes it possible to connect a large number of drives to the RAID controller, directly and through expanders. However, the actual number of drives that you can attach depends on the limits listed in [Table 1.2](#) rather than by the actual RAID volume capacity.

The maximum numbers in [Table 1.2](#) depend on how many physical devices you have connected to the controller. For example, the maximum number of arrays per controller is equal to the number of physical disks supported by the controller up to the limit of 16 arrays per controller. In addition, though you can have up to 16 virtual disks per array, and up to 16 arrays per controller, there is a limit of 32 virtual disks per controller.

### **1.6.3    SATA II Features**

The following list describes the SATA II features of the ServeRAID M5014 and ServeRAID M5015 controllers:

- Supports SATA II data transfers of 3.0 Gbs/s
- Supports STP data transfers of 3.0 Gbs/s
- Provides a serial, point-to-point storage interface

- Simplifies cabling between devices
- Eliminates the master-slave construction used in parallel ATA
- Allows addressing of multiple SATA II targets through an expander
- Allows multiple initiators to address a single target (in a fail-over configuration) through an expander

## 1.6.4 PCI Express Performance

The following list describes the PCI Express performance features of the ServeRAID M5014 and ServeRAID M5015 controllers:

- Provides a PCI Express interface that:
  - Supports a dedicated PCI Express bus
  - Supports x8 lane configuration
  - Supports transfer rates of up to 5 Gb/s per lane
  - Complies with the *PCI Express Specification, Revision 2.0*
- Provides unequalled performance through the Fusion-MPT architecture
- Provides high throughput and low CPU utilization to offload the host processor

## 1.6.5 Usability Features

The following list describes the usability features of the ServeRAID M5014 and ServeRAID M5015 controllers:

- Simplifies cabling with point-to-point, serial architecture
- Supports smaller, thinner cables that do not restrict airflow
- Provides drive spin-up sequencing control
- Provides up to two LED signals for each PHY to indicate link activity and faults
- Provides an I<sup>2</sup>C interface for enclosure management
- Supports the external SAS Sideband signal SFF-8485 (SGPIO) interface

## 1.6.6 Flexibility Features

These features increase the flexibility of the ServeRAID M5014 and ServeRAID M5015 controllers:

- Supports a Flash ROM interface, a nonvolatile static RAM (NVSRAM) interface, and a pipelined synchronous burst SRAM (PSBRAM) interface
- Offers a flexible programming interface to tune I/O performance
- Allows mixed connections to SAS targets or SATA II targets
- Leverages compatible connectors for SAS connections and SATA II connections
- Allows grouping of up to four PHYs in a single quad port to form a wide port
- Allows programming of the World Wide Name

## 1.6.7 Drive Roaming

Drive roaming occurs when the physical disks are changed to different ports on the same controller. When the drives are placed on different channels, the controller detects the RAID configuration from the configuration data on the drives.

**Note:** In a clustering environment, drive roaming is supported within the same channel only.

Configuration data is saved in both the NVRAM on the RAID controller and on the drives attached to the controller. This action maintains the integrity of the data on each drive, even if the drives have changed their target ID.

**Note:** If you move a drive that is being rebuilt, the rebuild operation will restart, not resume.

Follow these steps to use drive roaming:

- Step 1. Turn off the power to the server and all physical disks, enclosures, and system components. Disconnect the power cords from the system.

- Step 2. Open the host system by following the instructions in the host system technical documentation.
- Step 3. Move the drives to different positions on the backplane to change the targets.
- Step 4. Determine the SAS target requirements.
- Step 5. Perform a safety check.
  - a. Make sure that the drives are inserted correctly.
  - b. Close the cabinet of the host system.
- Step 6. Reconnect the power cords to the system.
- Step 7. Turn on the power to the system.

The controller then detects the RAID configuration from the configuration data on the drives.

## 1.6.8 Drive Migration

Drive migration is the transfer of a set of drives in an existing configuration from one controller to another. The drives must remain on the same channel and must be reinstalled in the same order as in the original configuration. The controller to which you migrate the drives cannot have an existing configuration.

**Note:** Only complete configurations can be migrated; individual virtual disks cannot be migrated.

**Note:** Drive roaming and drive migration cannot be supported at the same time.

Follow these steps to migrate drives:

- Step 1. Make sure that you clear the configuration on the system to which you migrate the drives, to prevent a configuration data mismatch between the drives and the NVRAM.

**Note:** When you migrate drives, move only the disks that make up the virtual disk (not all of the physical disks in an array), so that you do not have an NVRAM mismatch error (providing a configuration is on the destination controller). The NVRAM mismatch error appears only if you move all of the drives to the other controller.

- Step 2. Turn off the power to the server and all physical disks, enclosures, and system components. Disconnect the power cords from the systems.
  - Step 3. Open the host system, following the instructions in the host system technical documentation.
  - Step 4. Remove the SAS cable connectors from the internal drives that you want to migrate.
    - a. Make sure that pin 1 on the cable matches pin 1 on the connector.
    - b. Make sure that the SAS cables conform to all SAS specifications.
  - Step 5. Remove the physical disks from the first system, and insert them into drive bays on the second system.
  - Step 6. Connect the SAS cables to the physical disks in the second system.
  - Step 7. Determine the SAS target requirements.
  - Step 8. Perform a safety check.
    - a. Make sure that all of the cables are attached correctly.
    - b. Make sure that the RAID controller is installed correctly.
    - c. Close the cabinet of the host system.
  - Step 9. Reconnect the power cords to the system.
  - Step 10. Turn on the power to the system.

The controller detects the RAID configuration from the configuration data on the drives.
- 

## 1.7 Hardware Specifications

You can install your ServeRAID M5014 and ServeRAID M5015 controllers in a computer with a mainboard that has a PCI Express slot. [Table 1.3](#) describes the hardware configuration features of the controllers.

**Table 1.3    ServeRAID M5014/M5015 SAS/SATA Controller Specifications**

<b>Specification</b>	<b>ServeRAID M5014/M5015 SAS/SATA Controllers</b>
RAID Levels	0, 1, 5, 10, and 50
Devices Supported per Port	Up to 122 SAS or SATA II devices (such as drives and expanders)
Ports	Eight internal
Data Transfer Rate	Up to 6 Gb/s per phy
Bus	PCI Express 2.0
Cache Function	Write-back, write-through, adaptive read ahead, non-read ahead, read ahead, cache I/O, direct I/O
Multiple Virtual Disks/ Arrays per Controller	Up to 40 virtual disks per controller or per logical array
Online Capacity Expansion	Yes
Dedicated and Global Hot Spares	Yes
Hot Swap Devices Supported	Yes
Non-Disk Devices Supported	Yes
Mixed Capacity Physical Disks Supported	Yes
Number of Internal Connectors	Two (x4 SAS Port) SFF-8087 Mini SAS 8i connectors
Hardware Exclusive OR (XOR) Assistance	Yes
Direct I/O	Yes
Architecture	Fusion-MPT

---

## 1.8 Technical Support

See the *Warranty and Support Information* document for information about the technical support available for this product.



# Chapter 2

## ServeRAID Controller Hardware Installation

---

This chapter describes the procedures used to install the ServeRAID M5014 and ServeRAID M5015 SAS/SATA controllers. It consists of the following sections:

- [Section 2.1, “Requirements”](#)
- [Section 2.2, “Quick Installation”](#)
- [Section 2.3, “Detailed Installation”](#)
- [Section 2.4, “SAS Device Cables”](#)
- [Section 2.5, “After Installing the Controller”](#)
- [Section 2.6, “Replacing a Failed Controller Containing Data in the Battery Backup Unit”](#)

---

## 2.1 Requirements

The following items are required for installation:

- A ServeRAID M5014 or ServeRAID M5015 SAS/SATA controller
- A host system with an available PCI Express expansion slot
- The *ServeRAID-M Support* CD containing the documentation
- The necessary internal cables
- SAS physical disks or SATA II physical disks (Mechanical or Solid State Devices, SSDs)

**Note:** For optimal performance, use an uninterruptible power supply.

---

## 2.2 Quick Installation

The following steps are for quick installation of your controller. These steps are for experienced computer users/installers. [Section 2.3, “Detailed Installation,”](#) contains the steps for all others to follow.

- Step 1. Review all safety information provided with the server; then, turn off the power to the server and all of the attached devices, and unplug the server and the device power cords.
- Step 2. Open the cabinet of the host system by following the instructions in the host system technical documentation.
- Step 3. Install the controller in the server and connect the SAS devices or the SATA II devices to it. Make sure that the cables you use conform to all specifications.
- Step 4. Perform a safety check.
  - a. Make sure that all cables are properly attached
  - b. Make sure that the controller is installed correctly
  - c. Close the cabinet of the host system
- Step 5. Reconnect the power cords to the system and to all attached devices.
- Step 6. Turn on the power to the system after you complete the safety check.

---

## 2.3 Detailed Installation

This section provides detailed instructions for installing a ServeRAID M5014 or ServeRAID M5015 controller.

- Step 1. Unpack the Controller

Unpack and remove the controller. Inspect it for damage. If it appears damaged, or if any of the following items are missing, contact your place of purchase. The controller is shipped with the following items:

- A CD containing an electronic version of this *User’s Guide* and other related documentation

- Warranty information

**Step 2. Turn off the Power to the System**

Review all safety information provided with the computer; then, turn off the power to the computer, unplug the power cords from the power supplies, disconnect the computer from the network, and remove the computer cover. See the documentation provided with the computer for instructions. Before you install the controller, make sure that the computer is disconnected from the power and from any networks.

**Step 3. Review the Controller Connectors**

Refer to [Chapter 3, “ServeRAID M5014/M5015 SAS/SATA Controller Characteristics”](#) for a diagram of the ServeRAID M5014/M5015 controller with its connectors.

**Step 4. Review the Controller Limitations**

Review [Section 1.2.1, “Controller Limitations”](#) before you install the controller in the system.

**Step 5. Check the Battery Backup Unit**

Make sure that the ServeRAID M5000 Series Battery Assembly is present.

**Step 6. Install the Controller**

Select a PCI Express slot and align the controller’s PCI Express bus connector to the slot. Press down gently but firmly to ensure that the card is properly seated in the slot. Secure the bracket to the computer chassis.

[Figure 2.1](#) shows the installation of the ServeRAID M5014/M5015 controller in a PCI Express slot.

**Note:** Some PCI-E slots support PCI-E graphics cards only. If a RAID controller is installed one of those slots, the controller will not function.

**Attention:** To avoid damage to the computer, always remove the controller from the PCI Express slot before you relocate or ship the computer.

**Figure 2.1 ServerRAID M5014/M5015 Controllers Installation in a PCI Express Slot**

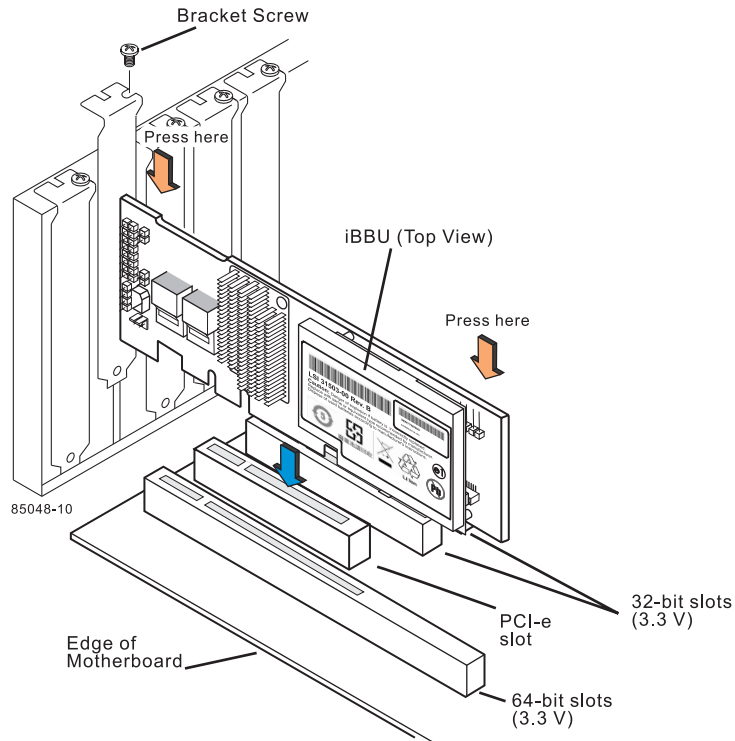

**Step 7. Configure and Install the SAS Devices, the SATA II Devices, or Both in the Host Computer Case**

Configure the SAS devices, SATA II devices, or both, and install them in the external enclosure.

**Note:** See the documentation for the external devices for pre-installation configuration requirements.

**Step 8. Connect the SAS Devices, the SATA II Devices, or Both to the Controller**

Use SAS cables to connect SAS devices, SATA II devices, or both to the controller. Refer to [Section 2.4, “SAS Device Cables”](#) for SAS cable information. Refer to [Section 2.4.1, “Connecting the ServeRAID M5014 or ServeRAID M5015 SAS/SATA Controller to Physical Drives,”](#) for details on connecting the controller to the physical disks and the expanders.

The maximum cable length is six meters. You can connect one device per SAS PHY unless you use an expander.

System throughput problems can occur if the SAS cables are not the correct type. To minimize the potential for problems:

- a. Use cables no longer than six meters (using shorter cables is preferred)
- b. Use cables that meet the SAS specification
- c. Route the SAS cables carefully

**Step 9. Turn on the Power to the System**

Reinstall the computer cover and reconnect the AC power cords; then, turn on the power to the computer.

Make sure that the power is turned on to the SAS devices and the SATA II devices before or at the same time as the host computer. If the power is turned on to the computer before it is turned on to the devices, the computer might not recognize the devices.

For the United Extensible Firmware Interface (UEFI), no BIOS message displays. Press F1 to enter System Setup. Refer to your system user's guide for specific configuration information.

Under other interfaces or operating systems, a BIOS message appears during boot. The firmware takes several seconds to initialize. The configuration utility prompt times out after several seconds. The second portion of the BIOS message displays the controller number, firmware version, and cache SDRAM size. The numbering of the controller follows the PCI slot scanning order used by the host mainboard.

**Step 10. Run the WebBIOS Configuration Utility**

Run the WebBIOS Configuration Utility to configure the physical arrays and the logical drives. When the message `Press <Ctrl><H> for WebBIOS` appears on the screen, press CTRL+H immediately to run the utility.

**Step 11. Install the Operating System Driver**

The controller can operate under various operating systems. To operate under these operating systems, you must install the software drivers. You can find and download the latest drivers

at <http://www.ibm.com/support/>. For updates, click **Downloads and drivers**.

Device driver updates are made available periodically. To ensure that you have the current version of the driver, download the latest driver at <http://www.ibm.com/support/>. See the readme file that accompanies the driver for any updated information.

For details on installing the driver, refer to the *ServeRAID-M Device Driver Installation User's Guide* on the *ServeRAID-M Support CD*. Be sure to use the latest Service Packs provided by the operating system manufacturer and to review the `readme` file that accompanies the driver.

---

## 2.4 SAS Device Cables

This section describes the cables used on the controller and provides step-by-step instructions for connecting SAS physical drives and/or SATA II physical drives to the controller. The SAS protocols and the SATA II protocols use a thin, 7-wire connector instead of the 68-wire SCSI cable or 26-wire ATA cable.

**Note:** Use only straight SAS cables, not cross-over SAS cables.

**Figure 2.2** displays the SAS cable that connects the internal connectors on the controller to SAS drives.

**Figure 2.2 Internal SAS Cable for Connection to SAS Physical Drives or SATA II Physical Drives**

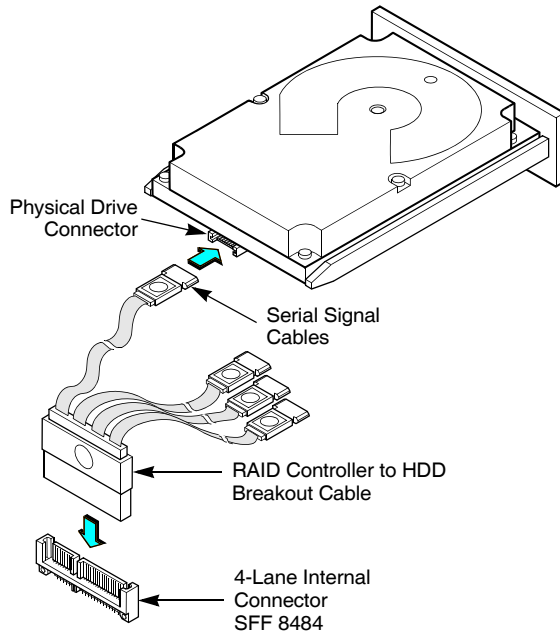

Figure 2.3 displays the SATA II device plug connector used to connect a controller with internal connectors to the host receptable connector on a backplane. A SATA II connector consists of a signal connector and a power connector.

**Figure 2.3 SATA II Connectors**

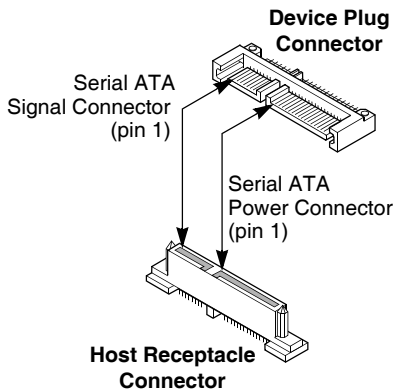
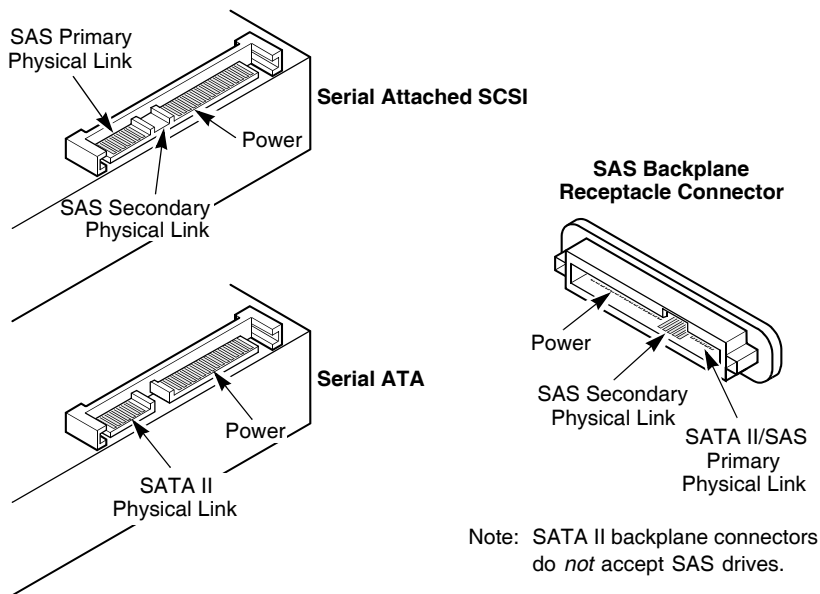

Figure 2.4 shows SAS connectors and SATA II connectors on SAS physical drives and SATA II physical drives, respectively. Cables are used for connection between internal connectors on the controller and connectors on SAS drives and/or SATA II drives, respectively. Both SAS physical drives and SATA II physical drives can connect to SAS backplane receptacle connectors. The difference between the SAS connector and SATA II connector is the bridge between the SAS primary physical link and the power connector on the SAS controller, which the SATA II connector does not have.

**Note:** SAS backplane connectors can accept SAS physical drives or SATA II physical drives, but SATA II backplane connectors *cannot* accept SAS drives.

**Figure 2.4 SAS Plugs, SATA II Plugs, and SAS Backplane Receptacle Connector**



## 2.4.1 Connecting the ServeRAID M5014 or ServeRAID M5015 SAS/SATA Controller to Physical Drives

This subsection provides step-by-step instructions for connecting your ServeRAID M5014 or ServeRAID M5015 controller to the SAS physical



drives and the SATA II physical drives. [Figure 2.5](#) shows how to connect the internal SAS cable from the controller to the drives.

Follow these steps to connect the controller with internal connectors to a physical drive.

- Step 1. Plug the connector on the internal cable into the internal connector on the controller.
- Step 2. Plug the connector on the other end of the internal cable into the connector on the SAS physical drive or the SATA II physical drive.
- Step 3. If you have another physical drive, connect it to another plug on the internal cable.

You can connect other devices if the cable has more connectors.

**Figure 2.5 Connecting the ServeRAID M5014/M5015 Controller Internal Connectors to a Physical Drive**

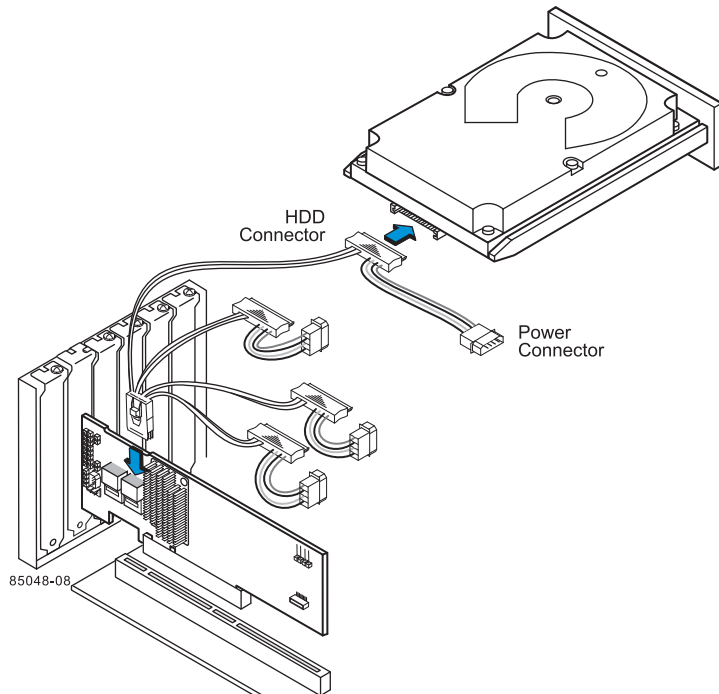

---

## 2.5 After Installing the Controller

After the you install the controller, you must configure it and install the operating system driver. The *ServeRAID-M Software User's Guide* instructs you on the configuration options and how to set them on your controller. The *ServeRAID-M Device Driver Installation User's Guide* provides detailed installation instructions for operating system drivers.

---

## 2.6 Replacing a Failed Controller Containing Data in the Battery Backup Unit

The ServeRAID M5000 Series Battery Assembly is a cache memory module with an integrated battery pack. The module provides an uninterrupted power source to the module if the power is unexpectedly interrupted while cached data is still present. If the power failure results from the failure of the controller, then you can move the battery backup unit to a new controller and recover the data. The replacement controller must have a cleared configuration.

**Note:** See the *Warranty and Support Information* document for the replacement battery part number and battery-disposal instructions.



**CAUTION:**

**The battery is a lithium ion battery. To avoid possible explosion, do not burn. Exchange only with the IBM-approved part. Recycle or discard the battery as instructed by local regulations. In the United States, IBM has a process for the collection of this battery. For information, call 1-800-426-4333. Have the IBM part number for the battery unit available when you call. (C007)**

Follow these steps to replace a failed controller with data in the transportable battery backup unit.

- Step 1. Review all safety information provided with the server; then, power down the server and the drives.

- Step 2. Remove the failed controller from the system.
- Step 3. Remove the ServeRAID M5000 Series Battery Assembly from the failed controller.
- Step 4. Insert the battery backup unit into the replacement controller.
- Step 5. Insert the replacement controller into the system.
- Step 6. Turn on the power to the system.

The controller then reads the disk configuration into NVRAM and flushes the cached data to the virtual disks.



# Chapter 3

## ServeRAID M5014/M5015

### SAS/SATA Controller

### Characteristics

---

This chapter describes the characteristics of the ServeRAID M5014 and ServeRAID M5015 SAS/SATA controllers. It consists of the following sections:

- [Section 3.1, “ServeRAID M5014/M5015 SAS/SATA Controller Descriptions”](#)
  - [Section 3.2, “Characteristics of the ServeRAID M5014/M5015 Controllers”](#)
  - [Section 3.3, “Technical Specifications”](#)
- 

## 3.1 ServeRAID M5014/M5015 SAS/SATA Controller Descriptions

The ServeRAID M5014 and ServeRAID M5015 SAS/SATA controllers are dual PHY, SAS PCI Express adapters and are used in systems with a PCI Express slot. PCI Express goes beyond the PCI specification in that it is intended as a unifying I/O architecture for various systems: desktops, workstations, mobile, server, communications, and embedded devices.

The ServeRAID M5014 and ServeRAID M5015 controllers have one LSISAS2108 ROC (RAID-on-chip) processor that controls eight external SAS/SATA ports through two x4 SAS external connectors.

### 3.1.1 Board Layout and Connector Information

This subsection provides the board layout and connector information for the controllers. The following subsections provide graphics and connector information for the controller.

The controller has eight internal SAS/SATA connectors. [Figure 3.1](#) displays the connectors on the controller, while are described on [Table 3.1](#).

**Figure 3.1 Card Layout for the ServeRAID M5014/M5015 RAID Controllers**

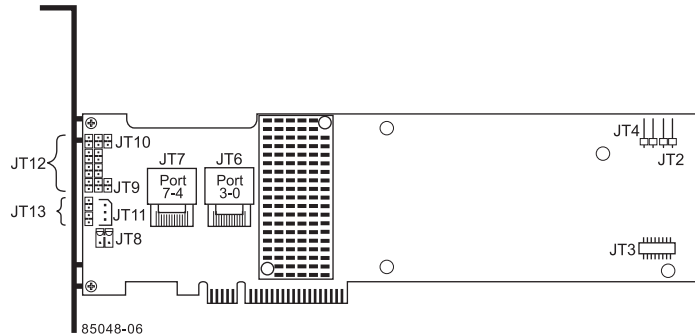

**Table 3.1 ServeRAID M5014 and ServeRAID M5015 Controllers Connectors**

Connector	Description	Type	Comments
JT1	Write-pending Indicator (dirty cache) LED connector	2-pin connector	Connects to an LED that indicates when the data in the cache has yet to be written to the storage devices. Used when the write-back feature is enabled.
JT2	SAS Activity LED header	2-pin connector	Connects to an LED that indicates drive activity.
JT3	Battery Backup Unit (BBU) connector	20-pin connector	Connects the BBU directly to the controller.
JT4	Global Drive Fault LED header	2-pin connector	Connects to an LED that indicates whether a drive is in a fault condition.
JT6	x4 SAS Ports 3–0	Mini SAS 4i connector	Connects the cables from the controller to SAS drives or SATA II drives, or a SAS expander.
JT7	x4 SAS Ports 7–4	Mini SAS 4i connector	Connects the cables from the controller to SAS drives or SATA II drives, or a SAS expander.

**Table 3.1 ServeRAID M5014 and ServeRAID M5015 Controllers Connectors (Cont.)**

Connector	Description	Type	Comments
JT8	ServeRAID M5000 Series Advanced Feature Key header	2-pin shielded header	Enables support for RAID 6 configurations and self-encrypting disks (SED).
JT9	Set Factory Defaults connector	2-pin connector	Returns the board settings to the defaults set in the factory.
JT10	LSI Test header	2-pin connector	Reserved for IBM use.
JT11	IPMI-style SMBus (System Management)/I <sup>2</sup> C header	3-pin shielded header	Provides enclosure management support.
JT12	Individual Drive Fault LED header for Eight Phys (0-7)	16-pin connector	<p>Indicates drive faults. There is one LED per port. When lit, each LED indicates the corresponding drive has failed or is in the Unconfigured-Bad state. Refer to the <i>ServeRAID-M SAS Software User's Guide</i> for more information.</p> <p>The LEDs function in a direct-attach configuration (there are no SAS expanders). Direct attach is defined as a maximum of one drive connected directly to each port. This header is used for controllers with internal SAS ports.</p>
JT13	Universal Asynchronous Receiver/Transmitter (UART) debugging	4-pin connector	Reserved for IBM use.

---

## 3.2 Characteristics of the ServeRAID M5014/M5015 Controllers

Table 3.2 shows the general characteristics of the ServeRAID 5014 and ServeRAID M5015 SAS/SATA controllers.

**Table 3.2    ServeRAID M5014 and ServeRAID M5015 SAS/SATA Controllers Characteristics**

Flash ROM <sup>1</sup>	Serial EEPROM <sup>2</sup>	SAS Data Transfers	SCSI Features	SCSI Termination
Yes	Yes	Up to 6 Gb/s per port	Plug and Play Scatter/Gather Activity LED	Active

1. For boot code and firmware.
2. For BIOS configuration storage.

The controllers ensure data integrity by intelligently validating the compatibility of the SAS domain. The controllers uses Fusion-MPT architecture, which allows for thinner drivers and better performance.

---

## 3.3 Technical Specifications

The design and implementation of the ServeRAID M5014 and ServeRAID M5015 SAS/SATA controllers minimize electromagnetic emissions, susceptibility to radio frequency energy, and the effects of electrostatic discharge. The controller carries the following marks and certifications:

- CE mark
- C-Tick mark
- FCC Self-Certification logo
- Canadian Compliance Statement
- Korean MIC
- Taiwan BSMI
- Japan VCCI



In addition, the controller meets the requirements of CISPR Class B.

The ServeRAID M5014 SAS/SATA controller, the ServeRAID M5015 SAS/SATA controller, and the ServeRAID M5000 Series Battery Assembly are CSA C22.2 No. 60950-1, UL 60950-1 First Edition listed Accessory, UL file number E257743.

### 3.3.1 Controller Specifications

[Table 3.3](#) lists the specifications for the ServeRAID M5014 and ServeRAID M5015 SAS/SATA controllers.

**Table 3.3    ServeRAID M5014 and ServeRAID M5015 SAS/SATA Controllers Specifications**

Specification	ServeRAID M5014/M5015 SAS/SATA Controllers
Processor (PCI Express Host Controller to PCI Secondary I/O Controller)	LSISAS2108 ROC device with Integrated PowerPC processor
Operating Voltage	+3.3 V, +12 V
Card Size	Low profile PCI Express adapter card size (2.713" x 6.6")
Array Interface to Host	PCI Express Rev 2.0
Type of Drives Supported	Serial Attached SCSI (SAS) and Serial ATA II (SATA II)
PCI Express Bus Data Transfer Rate	<ul style="list-style-type: none"> <li>• Up to 5 Gb/s per lane</li> <li>• x8 lane width</li> <li>• Up to 2 Gbytes/s per direction for SAS x4 cards (4 Gbytes/s total)</li> </ul>
Serial Port	3-pin RS232-compatible connector (for manufacturing use only)
SAS Controller(s)	One LSISAS 2108 Single SAS controller
SAS Bus Speed	6 Gb/s
SAS Ports	Two SAS connectors with four SAS ports each

**Table 3.3    ServeRAID M5014 and ServeRAID M5015 SAS/SATA Controllers Specifications (Cont.)**

Specification	ServeRAID M5014/M5015 SAS/SATA Controllers
Cache Configuration	<p><b>ServeRAID M5014</b> - Integrated 256 Mbyte 40-bit Double Data Rate II ECC 800 MHz SDRAM</p> <p><b>ServeRAID M5015</b> - Integrated 512 Mbyte 72-bit Double Data Rate II ECC 800 MHz SDRAM</p>
Size of Flash ROM for Firmware	8 Mbytes
Nonvolatile Random Access Memory (NVRAM)	32 Kbytes for storing RAID configuration

### 3.3.2    Array Performance Features

Table 3.4 shows the array performance features for the ServeRAID M5014 and ServeRAID M5015 SAS/SATA controllers.

**Table 3.4    Array Performance Features**

Specification	ServeRAID M5014/M5015 Controller
PCI Express Host Data Transfer Rate	5 Gb/s per lane
Drive Data Transfer Rate	6.0 Gb/s per lane
Maximum Scatter/Gathers	26 elements
Maximum Size of I/O Requests	6.4 Mbytes in 64 Kbyte stripes
Maximum Queue Tags per Drive	As many as the drive can accept
Stripe Sizes	8, 16, 32, 64, or 128 Kbyte
Maximum Number of Concurrent Commands	255

### 3.3.3    Fault Tolerance

Table 3.5 shows the fault tolerance features of the ServeRAID M5014 and ServeRAID M5015 SAS/SATA controllers.

**Table 3.5 Fault Tolerance Features**

Specification	ServeRAID M5015 SAS/SATA Controllers
Support for SMART <sup>1</sup>	Yes
Optional Battery Backup for Cache Memory	ServeRAID M5000 Series Battery Assembly. <3.7V/500mAH battery pack; up to 48 hours of data retention <ul style="list-style-type: none"> <li>– Battery-protected backup for up to 256 Mbytes of data for the ServeRAID M5014 controller</li> <li>– Battery-protected backup for up to 512 Mbytes of data for the ServeRAID M5015 controller</li> </ul>
Drive Failure Detection	Automatic
Drive Rebuild Using Hot Spares	Automatic
Parity Generation and Checking	Yes

1. The Self Monitoring Analysis and Reporting Technology (SMART) detects up to 70 percent of all predictable drive failures. In addition, SMART monitors the internal performance of all motors, heads, and drive electronics.

### 3.3.4 Power Supply Requirements for the ServeRAID M5014/M5015 Controllers

All power is supplied to the controllers through the PCI Express 3.3V rails and the 12V rail. Onboard switching regulator circuitry operating from the 3.3V rails and the 12V rail provide the necessary voltages. The following states determine the typical current consumption of the controller:

- State 1: During a hard reset
- State 2: During a disk stress test
- State 3: While sitting idle at the DOS prompt

The supply voltages are 12V ± 8 percent (from PCI edge connector only) and 3.3V ± 9 percent (from PCI edge connector only). [Table 3.6](#) lists the power supply for the controller for each of the three states at the different voltages.

**Table 3.6 Power Supply for the ServeRAID M5014/M5015 Controllers**

PCI Edge Connector	State 1	State 2	State 3
3.3V supply	330mA	330mA	330mA
+12V supply	1.00A	1.81A	1.53A
3.3V auxiliary supply	30mA	30mA	30mA

Note: +12V is used in the charging circuitry for the battery pack on the optional battery-backed daughter card. If the daughter card is mounted, the following power consumption figures apply:

- During fast charging of the battery pack: 230mA in +12V current

### 3.3.5 Operating and Non-operating Conditions

The operating (thermal and atmospheric) conditions for the ServeRAID M5014 and ServeRAID M5015 SAS/SATA controllers are:

- Relative humidity range is 5% to 90% noncondensing
- Airflow must be at least 200 linear feet per minute (LFPM) to avoid operating the Intel IOP333 processor above the maximum ambient temperature
- Temperature range: +10 °C to +60 °C without battery backup
- Temperature range: +10 °C to +40 °C with battery backup

The parameters for the non-operating (such as storage and transit) environment for the controller are:

- Temperature range: -30 °C to +80 °C without battery backup
- Temperature range: 0 °C to +45 °C with battery backup

### 3.3.6 Safety Characteristics

The ServeRAID M5014 and ServeRAID M5015 SAS/SATA controllers meet or exceed the requirements of UL flammability rating 94 V0. Each bare board is also marked with the supplier name or trademark, type, and UL flammability rating. The board is installed in a PCI Express bus slot, so all voltages are lower than the SELV 42.4 V limit.

# Chapter 4

## Intro to the ServeRAID M5000 Series Battery Assembly

---

The ServeRAID M5000 Series Battery Assembly is for use with the high-performance ServeRAID M5015 controller. The battery backup unit (BBU) protects the integrity of the cached data on controller by providing backup power if there is a complete AC power failure or a brief power outage. The ServeRAID M5000 Series Battery Assembly provides an inexpensive alternative to using an uninterruptible power supply (UPS).

Writing a block of data to cache memory is much faster than writing it to a storage device. The controller then writes the cached data to the storage device when system activity is low or when the cache is getting full. The risk of using write-back cache is that the cached data can be lost if the AC power fails before it has been written to the storage device. This risk factor is eliminated when the controller has an onboard battery assembly.

The ServeRAID M5000 Series Battery Assembly monitors the voltage level of the DRAM modules installed on the controller. If the voltage drops below a predefined level, the battery backup module switches the memory power source from the controller to the battery pack attached to the battery assembly. As long as the voltage level stays below the predefined value, the battery assembly provides power for memory. If the voltage level returns to an acceptable level, the battery assembly switches the power source back to the controller, and all incomplete writes to storage devices are completed with no data loss.

The ServeRAID M5000 Series Battery Assembly has built-in functionality to charge the battery pack automatically and to communicate battery status information such as voltage, temperature, and current, to the host computer system.



**CAUTION:**

The battery is a lithium ion battery. To avoid possible explosion, do not burn. Exchange only with the IBM-approved part. Recycle or discard the battery as instructed by local regulations. In the United States, IBM has a process for the collection of this battery. For information, call 1-800-426-4333. Have the IBM part number for the battery unit available when you call. (C007)

# Chapter 5

## Installing a ServeRAID M5000 Series Battery Assembly

---

This chapter explains how to install a ServeRAID M5000 Series Battery Assembly on the ServeRAID M5014 controller.

**Note:** The ServeRAID M5000 Series Battery Assembly is pre-installed on the ServeRAID M5015 controller.

**Attention:** Electrostatic discharge can damage the battery assembly and the controller on which it is installed. Always ground yourself and/or use a ground strap before you touch the controller or the battery assembly. Perform all installation work at an ESD safe workstation that meets the requirements of EIA-625—“Requirements for Handling Electrostatic Discharge Sensitive Devices.” Follow the ESD recommended practices in the latest revision of IPC-A-610.

The battery in the battery assembly must charge for at least six hours during fast charge under normal operating conditions. To protect your data, the firmware changes the Write Policy to *write-through* until the battery unit is sufficiently charged. When the battery unit is charged, the SAS/SATA controller firmware changes the Write Policy to *write-back* to take advantage of the performance benefits of data caching.

The maximum ambient temperature for battery packs is 0° C to 45° C.

**Note:** The temperature of the battery pack during fast charge is typically 15–20 degrees higher than the ambient temperature. Therefore, for the fast charge circuit to complete a fast charge cycle, ambient temperature should be less than 40° C. If the ambient temperature is greater than 40° C, the fast charge cycle could terminate prematurely.

## 5.1 Installing the ServeRAID M5000 Series Battery Assembly on a Controller

The ServeRAID M5000 Series Battery Assembly is compatible with systems that offer auxiliary power. Battery charging and recharging take place automatically. The battery assembly mounts directly to the controller using a small board-to-board connector (daughtercard).

Figure 5.1 displays the top view and the bottom view of the card. (The “top” side is the side you can see after you install the battery assembly on the controller.) Note that this unit combines a battery pack with a daughtercard.

**Figure 5.1** ServeRAID M5000 Series Battery Assembly

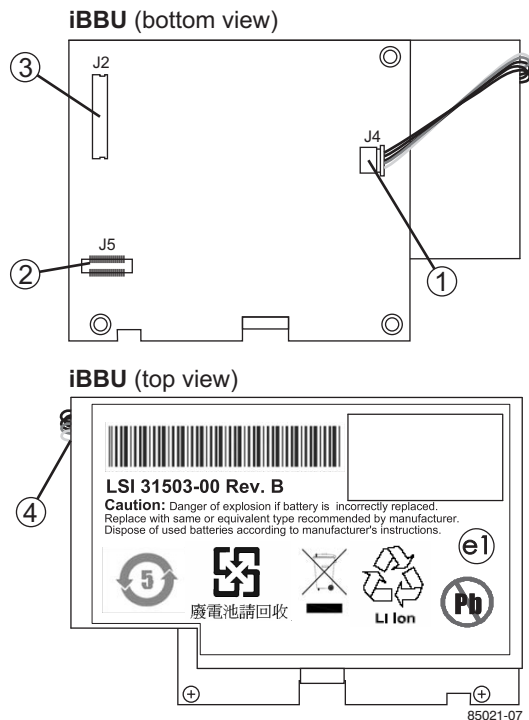

1 - J4 battery pack harness connector

2 - J5 board-to-board connector



3 - J2 connector

4 - Battery pack harness



**CAUTION:**

**The battery is a lithium ion battery. To avoid possible explosion, do not burn. Exchange only with the IBM-approved part. Recycle or discard the battery as instructed by local regulations. In the United States, IBM has a process for the collection of this battery. For information, call 1-800-426-4333. Have the IBM part number for the battery unit available when you call. (C007)**

If the ServeRAID M5014 controller is already installed in a computer, follow these steps to remove it before you install the battery assembly:

1. Shut down the computer, turn off the power, and unplug the power cords.
2. Remove the cover from the computer according to the instructions in the system user's manual so you can access the controller.
3. Ground yourself before you touch the controller.
4. Unplug all cables from the controller, remove the screw attaching the bracket to the computer case, and carefully remove the controller from the slot.
5. Place the controller on a flat, clean, static-free surface, and continue with the next section.

Perform the following steps to mount the battery assembly directly to the controller using the daughtercard. (All components are installed on the bottom of the card. The battery is installed on the top. The maximum height of components installed on the battery assembly is 0.125".)

1. Ground yourself, and remove the daughtercard from the package.
2. Insert the battery pack harness into the 5-pin J4 connector on the bottom of the battery assembly.

3. Hold the daughtercard so that the battery side is up and the J5 connector lines up with the J1 battery backup connector on the controller, as shown in [Figure 5.2](#).

**Figure 5.2 Installing the ServeRAID M5000 Series Battery Assembly on the ServeRAID M5014 Controller**

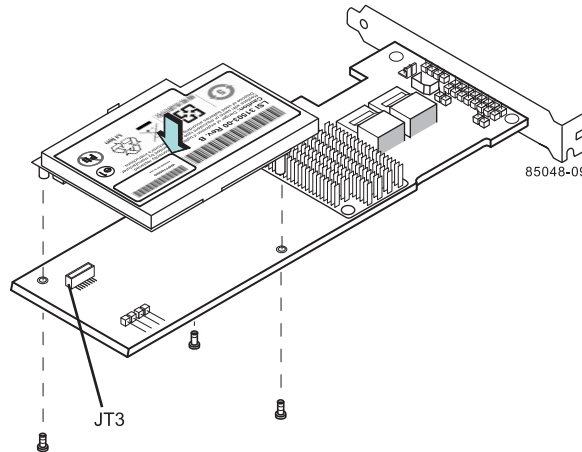

4. Carefully press the battery assembly onto the controller, so that the two connectors are firmly joined.
5. Secure the battery assembly to the controller with the screws and the standoffs in the three screwholes.

The standoffs are threaded at both ends and a screw goes into each end.

6. Use the Phillips-head screws that are provided to secure the battery assembly to the controller.

**Attention:** Center the screwdriver carefully to avoid stripping the screwhead. Do not over-tighten the screws.

7. Install the controller in the computer in the PCI Express slot, as shown in [Figure 5.3](#).

Press down gently, but firmly, to make sure that the controller is properly seated in the slot. The bottom edge of the controller must be flush with the slot.

**Attention:** *Never* apply pressure to the battery assembly when you insert the controller. Instead, press down only on the top edge of the controller, as shown in [Figure 5.3](#).

**Figure 5.3** Installing the ServeRAID M5014 Controller

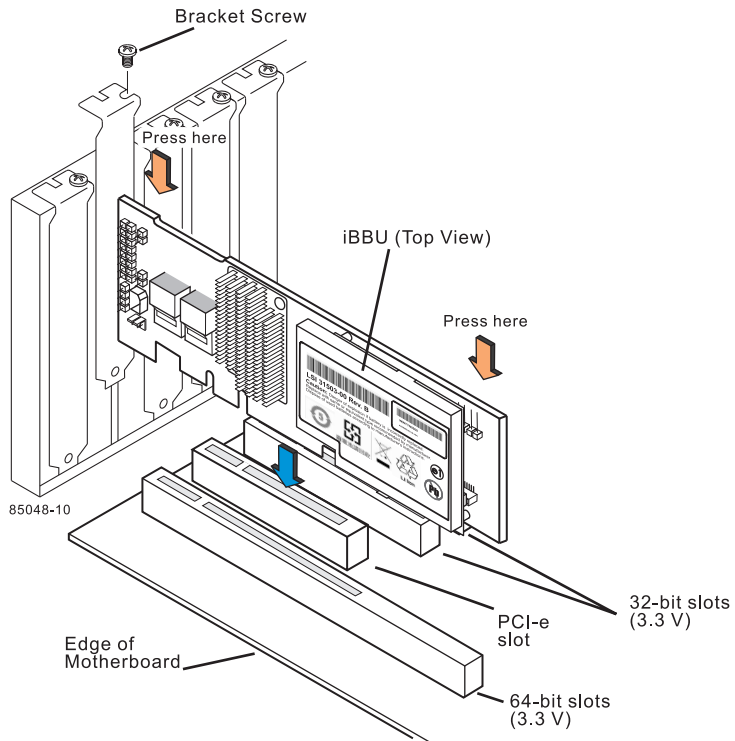

8. Attach the controller to the computer chassis with the bracket screw.
9. Attach the cables, as needed, to the connectors on the controller.
10. Reinstall the computer cover, reattach the power cords, and turn on the power to the computer.

**Attention:** See the *ServeRAID-M Software User's Guide* for information about running the RAID configuration utility and installing software drivers.



# Chapter 6

## Using the ServeRAID M5000 Series Battery Assembly

---

This chapter explains how to monitor and maintain the ServeRAID M5000 Series Battery Assembly for your ServeRAID M5014 or ServeRAID M5015 SAS/SATA controllers. Most of the battery assembly functions, such as battery recharging, occur automatically. Click on the following links to view instructions on how to use the battery assembly:

- [Section 6.1, “Monitoring the Battery Backup with the MegaRAID Configuration Utilities”](#)
- [Section 6.2, “Replacing the ServeRAID M5000 Series Battery Assembly”](#)
- [Section 6.3, “Transferring Cached Data from a Failed Controller”](#)
- [Section 6.4, “Resolving a Configuration Mismatch”](#)

You can monitor the battery status (temperature, voltage, and so on) in these MegaRAID<sup>®</sup> utility programs:

- WebBIOS Configuration Utility
- MegaCLI (Command Line Interface)
- MegaRAID Storage Manager (MSM)

The MegaRAID utilities display a counter showing the number of times the battery pack on the battery assembly has been recharged. When you install a new battery assembly, the battery recharge cycle counter for the battery assembly is automatically set to zero.

**Note:** For optimal performance, replace the battery assembly once a year.

This chapter describes only the battery assembly-related features of the MegaRAID configuration utility programs. For complete information on these utilities, see the *ServeRAID-M Software User's Guide*, IBM Document No. 46M1381.

---

## 6.1 Monitoring the Battery Backup with the MegaRAID Configuration Utilities

This section describes the MegaRAID configuration utilities you can use to monitor the condition of the installed ServeRAID M5000 Series Battery Assembly and to change the automatic learn mode options. They include the WebBIOS Configuration Utility, MegaCLI, and MegaRAID Storage Manager.

### 6.1.1 Monitoring the ServeRAID M5000 Series Battery Assembly with the WebBIOS Configuration Utility

The WebBIOS CU is a web-based utility for configuring and managing RAID volumes. Its operation is independent of the operating system because the utility resides in the MegaRAID BIOS. Follow these steps to monitor the status of an installed battery assembly with the WebBIOS utility:

1. Boot the system.
2. Start the WebBIOS CU by pressing CTRL+H when the prompt appears on the screen during boot-up.

The WebBIOS CU main menu screen appears.

3. Click **Controller Properties** on the WebBIOS CU main menu screen.

The first Controller Properties screen appears, as shown in [Figure 6.1](#).

**Figure 6.1 First Controller Properties Screen**



- Click **Next** to view the second Controller Properties screen.

The second Controller Properties screen appears, as shown in [Figure 6.2](#). The **Battery Backup** field at the top left of the screen indicates whether the battery backup assembly is present.

**Figure 6.2 Second Controller Properties Screen**

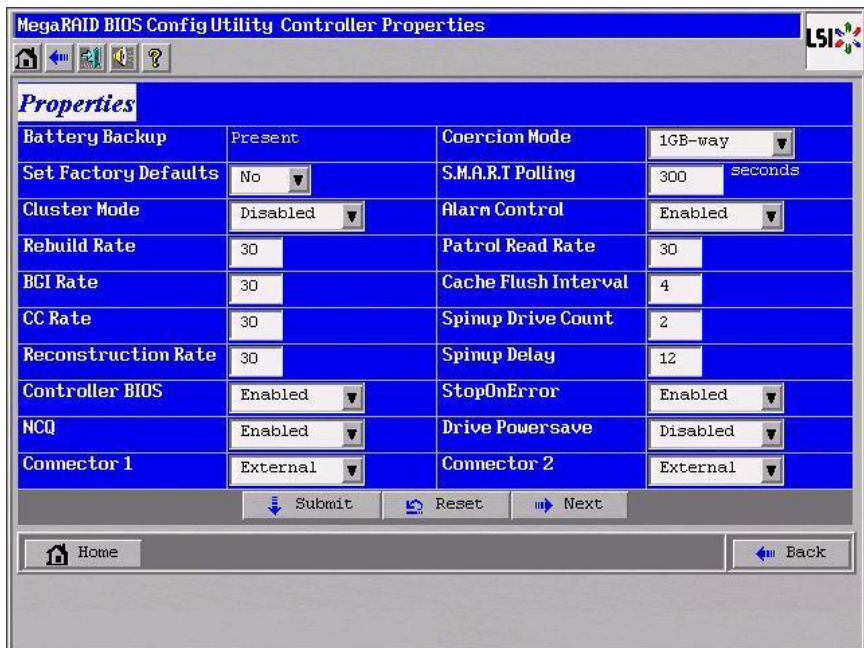

5. Click **Present** in the **Battery Backup** field.

The Battery Module screen appears, as shown in [Figure 6.3](#). This screen contains the following information:

- Battery information
- Design information
- Capacity information
- Auto Learn properties

**Figure 6.3 Battery Module Screen**

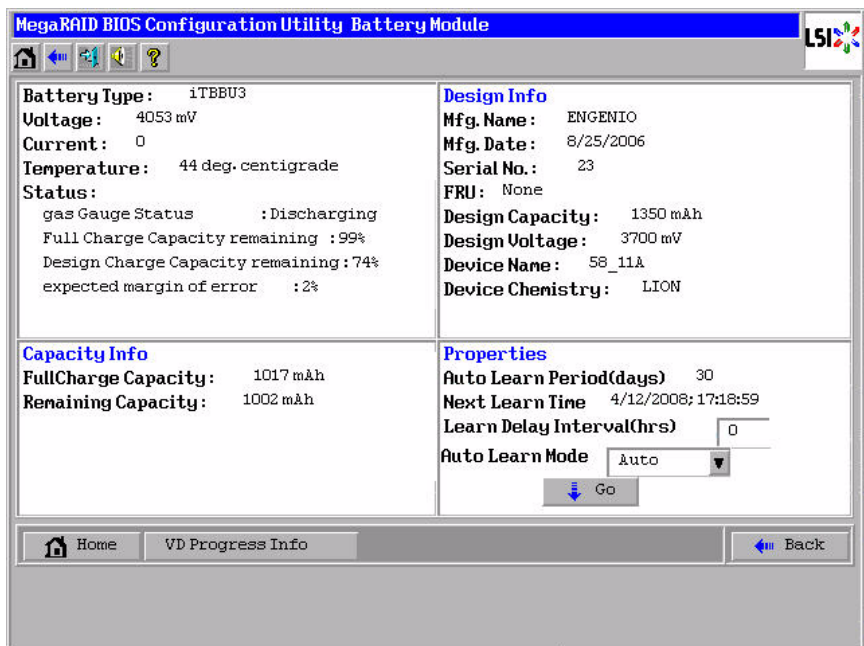

Most of the Battery Module properties are view-only and are self-explanatory.

In the lower right corner of the screen are the Auto Learn options. A *learning cycle* is a battery calibration operation performed by the controller periodically to determine the condition of the battery. You can change the learn delay interval and the auto learn mode.

**Note:** IBM recommends leaving the the learn delay interval and the auto learn mode at their default settings.



### 6.1.1.1 Setting the Learn Delay Interval

The learn delay interval is the length of the interval between automatic learning cycles. Perform the following steps to change the interval:

1. Open the drop-down menu in the **Auto Learn Mode** field.
2. Set the learn mode as `Auto` (the default).
3. Change the number of hours in the **Learn Delay Interval** field.

You can delay the start of the learn cycles for up to 168 hours (7 days).

4. Click **Go**

### 6.1.1.2 Setting the Learn Mode

You can start battery learn cycles manually or automatically. Perform the following steps to choose the learn mode:

1. Open the drop-down menu in the **Auto Learn Mode** field.
2. Set the learn mode as `Auto` (the default ) or `Manual`.
3. Click **Go**.

Note: IBM recommends 30 days for the interval between cycles.

Note: When you replace the battery assembly, the charge cycle counter is reset automatically.

## 6.1.2 Monitoring the ServeRAID M5000 Series Battery Assembly with the MegaCLI Utility

You can use the MegaCLI commands in this section to monitor the battery assembly and to select the settings for battery backup unit (BBU)-related options.

### 6.1.2.1 Display BBU Information

Use the command in [Table 6.1](#) to display complete information about the BBU for the selected controller(s).

**Table 6.1** Display BBU Information

---

<b>Convention</b>	<code>MegaCli -AdpBbuCmd -aN -a0,1,2 -aALL</code>
-------------------	---

---

**Table 6.1 Display BBU Information (Cont.)**

---

<b>Description</b>	Displays complete information about the BBU, such as status, capacity information, design information, and properties.
--------------------	--

---

**6.1.2.2 Display BBU Status Information**

Use the command in [Table 6.2](#) to display complete information about the status of the BBU, such as temperature and voltage, for the selected controller(s).

**Table 6.2 Display BBU Status Information**

---

<b>Convention</b>	MegaCli -AdpBbuCmd -GetBbuStatus -aN -a0,1,2 -aALL
<b>Description</b>	<p>Displays complete information about the BBU status, such as the temperature and voltage. The information displays in the following formats:</p> <p><b>BBU Status for Adapter: xx</b> Battery Type: XXXXXX(string) Voltage: xx mV Current: xx mA Temperature: xx C° Firmware Status: xx Battery state: xx</p> <p><b>Gas Gauge Status:</b> Fully Discharged: Yes/No Fully Charged: Yes/No Discharging: Yes/No Initialized: Yes/No Remaining Time Alarm: Yes/No Remaining Capacity Alarm: Yes/No Discharge Terminated: Yes/No Over Temperature: Yes/No Charging Terminated: Yes/No Over Charged: Yes/No</p> <p>Additional status information displays differently for iBBU™ and BBU.</p> <p><b>For iBBU:</b> Relative State of Charge: xx Charger System State: xx Charger System Ctrl: xx Charging Current: xx mA Absolute State of Charge: xx% Max Error: xx%</p> <p><b>For BBU:</b> Relative State of Charge: xx Charger Status: xx Remaining Capacity: xx mAh Full Charge Capacity: mAh isSOHGood: Yes/No</p>

---

### 6.1.2.3 Display BBU Capacity

Use the command in [Table 6.3](#) to display the BBU capacity for the selected controller(s).

**Table 6.3 Display BBU Capacity Information**

<b>Convention</b>	MegaCli -AdpBbuCmd -GetBbuCapacityInfo -aN -a0,1,2 -aALL
<b>Description</b>	Displays BBU capacity information. The information displays in the following format: BBU Capacity Info for Adapter: x Relative State of Charge: xx% Absolute State of Charge: xx% Remaining Capacity: xx mAh Full Charge Capacity: xx mAh Run Time to Empty: xxx Min Average Time to Empty: xxx Min Average Time to Full: xxx Min Cycle Count: xx Max Error: xx%

### 6.1.2.4 Display BBU Design Parameters

Use the command in [Table 6.4](#) to display BBU design parameters for the selected controller(s).

**Table 6.4 Display BBU Design Parameters**

<b>Convention</b>	MegaCli -AdpBbuCmd -GetBbuDesignInfo -aN -a0,1,2 -aALL
<b>Description</b>	Displays information about the BBU design parameters. The information displays in the following formats: BBU Design Info for Adapter: x Date of Manufacture: mm/dd, yyyy Design Capacity: xxx mAh Design Voltage: mV Serial Number: 0xhhhh Pack Stat Configuration: 0xhhhh Manufacture Name: XXXXXX(String) Device Name: XXXXXX(String) Device Chemistry: XXXXXX(String)

### 6.1.2.5 Display Current BBU Properties

Use the command in [Table 6.5](#) to display the current BBU properties for the selected controller(s).

**Table 6.5 Display Current BBU Properties**

<b>Convention</b>	MegaCli -AdpBbuCmd -GetBbuProperties -aN -a0,1,2 -aALL
<b>Description</b>	Displays current properties of the BBU. The information displays in the following formats: BBU Properties for Adapter: x Auto Learn Period: xxx Sec Next Learn Time: xxxx Sec Learn Delay Interval: xx Hours Auto-Learn Mode: Warn via Event/Disabled/Enabled

**6.1.2.6 Start BBU Learning Cycle**

Use the command in [Table 6.6](#) to start the BBU learning cycle on the selected controller(s). A learning cycle is a battery calibration operation performed by the controller periodically (approximately every three months) to determine the condition of the battery.

**Table 6.6 Start BBU Learning Cycle**

<b>Convention</b>	MegaCli -AdpBbuCmd -BbuLearn -aN -a0,1,2 -aALL
<b>Description</b>	Starts the learning cycle on the BBU. No parameter is needed for this option.

**6.1.2.7 Place Battery in Low-Power Storage Mode**

Use the command in [Table 6.7](#) to place the battery into Low-Power Storage mode on the selected controller(s). This saves battery power consumption.

**Table 6.7 Place Battery in Low-Power Storage Mode**

<b>Convention</b>	MegaCli -AdpBbuCmd -BbuMfgSleep -aN -a0,1,2 -aALL
<b>Description</b>	Places the battery in Low-Power Storage mode. The battery automatically exits this state after 5 seconds.

**6.1.2.8 Set BBU Properties**

Use the command in [Table 6.8](#) to set the BBU properties on the selected controller(s) after reading from the file.

**Table 6.8 Set BBU Properties**

<b>Convention</b>	MegaCli -AdpBbuCmd -SetBbuProperties -f<fileName> -aN -a0,1,2 -aALL
-------------------	---

**Table 6.8 Set BBU Properties (Cont.)**

---

<b>Description</b>	<p>Sets the BBU properties on the selected controller(s) after reading from the file. The information displays in the following formats: autoLearnPeriod = 1800Sec nextLearnTime = 12345678Sec Seconds past 1/1/2000 learnDelayInterval = 24hours Not greater than 7 days autoLearnMode = 0 0 – Enabled, 1 - Disabled, 2 – WarnViaEvent.</p> <p>1. NOTE: You can change only two of these parameters, learnDelayInterval and autoLearnMode.</p>
--------------------	---

---

### 6.1.3 Monitoring the Battery Backup with MegaRAID Storage Manager

When MegaRAID Storage Manager software is running, you can monitor the status of the ServeRAID M5000 Series Battery Assembly connected to controllers in the server.

If the battery assembly is operating normally, the icon looks like this: . If it has failed, a red dot appears next to the icon.

To show the properties for the battery backup unit (BBU), perform the following steps:

1. Click the **Physical** tab to open the physical view.
2. Select the BBU icon in the left panel.
3. Click the **Properties** tab.

The BBU properties, such as the battery type, temperature, and voltage, appear, as shown in [Figure 6.4](#).

**Figure 6.4 Battery Backup Unit Information**

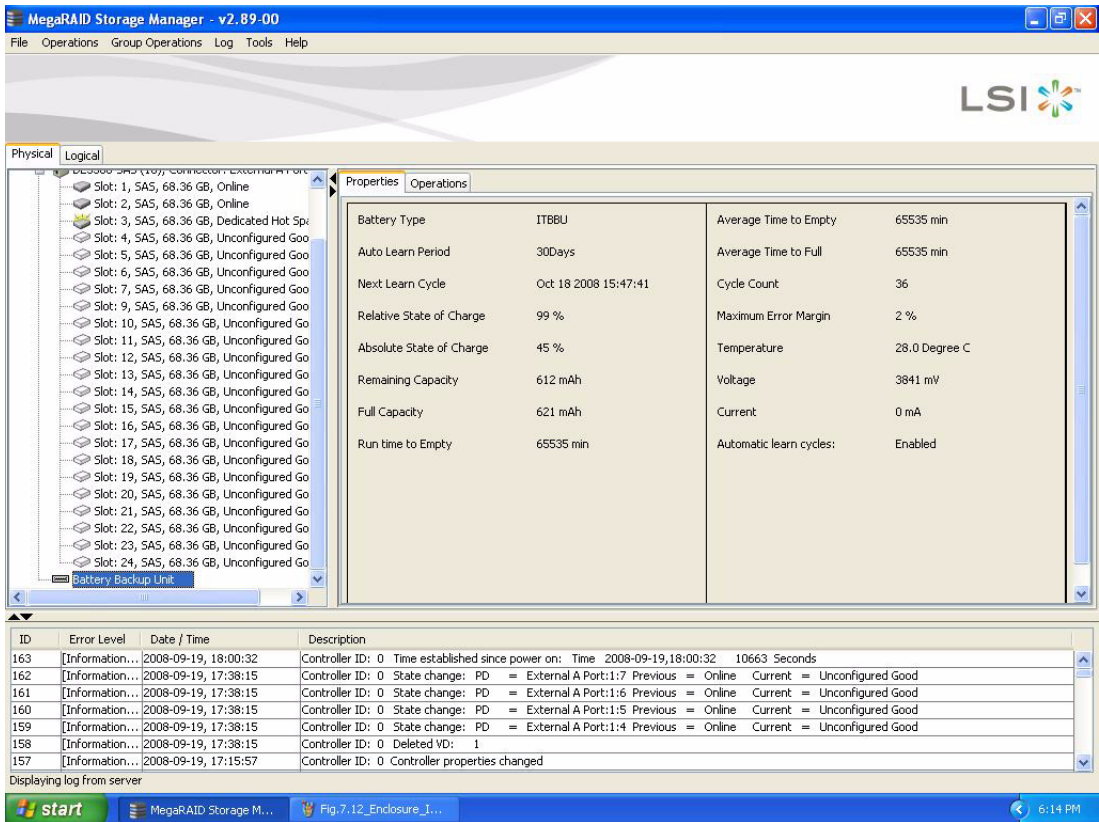

The BBU properties include the following:

- The number of times the BBU has been recharged (**Cycle Count**)
- The full capacity of the BBU, plus the percentage of its current state of charge, and the estimated time until it will be depleted
- The current BBU temperature, voltage, current, and remaining capacity
- If the battery is charging, the estimated time until it is fully charged

### 6.1.3.1 Battery Learn Cycle

Learn Cycle is a battery calibration operation performed by the controller periodically to determine the condition of the battery. You can start battery learn cycles manually or automatically. To choose automatic

battery learn cycles, enable automatic learn cycles. To choose manual battery learn cycles, disable automatic learn cycles.

If you enable automatic learn cycles, you can delay the start of the learn cycles for up to 168 hours (7 days). If you disable automatic learn cycles, you can start the learn cycles manually, and you can choose to receive a reminder to start a manual learn cycle.

### 6.1.3.2 Setting the Learn Cycle Properties

To set the learn cycle properties, perform the following steps:

1. Click the **Physical** tab to open the physical view.
2. Select the BBU icon in the left panel.
3. Click the **Operations** tab.

The BBU operations appear, as shown in [Figure 6.5](#).

**Figure 6.5 Battery Backup Unit Operations**

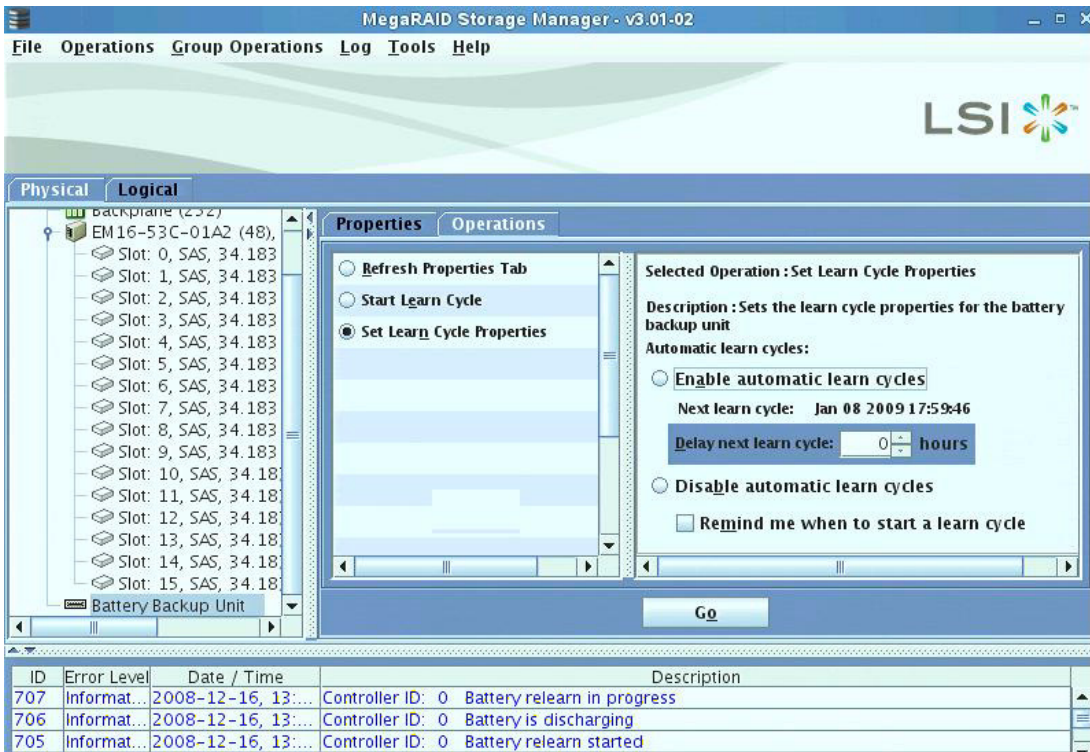

4. Select **Set Learn Cycle Properties**.

The options appear in the right frame.

5. To enable automatic learn cycles, click **Enable automatic learn cycles** and click **Go**.

You can delay the start of the next learn cycle by up to 7 days (168 hours) using the **Delay next learn cycle** field.

6. To disable automatic learn cycles, click **Disable automatic learn cycles** and click **Go**.

You can start the learn cycles manually. In addition, you can check the box next to the field **Remind me when to start a learn cycle** to receive a reminder to start a manual learn cycle.

### 6.1.3.3 Starting a Learn Cycle Manually

To start the learn cycle properties manually, perform the following steps:

1. Click the **Physical** tab to open the physical view.
2. Select the BBU icon in the left panel.
3. Click the **Operations** tab.

The BBU operations appear, as shown in [Figure 6.5](#).

4. Click **Start Learn Cycle** and click **Go**.

Another method to use the BBU operations is to right-click the BBU icon to open the operations menu and select **Start Learn Cycle**.

---

## 6.2 Replacing the ServeRAID M5000 Series Battery Assembly

For optimal performance, replace the ServeRAID M5000 Series Battery Assembly once a year. See the *Warranty and Support Information* document for the replacement battery part number.

When you install a new battery assembly, the battery recharge cycle counter for the battery assembly is automatically set to zero. For instructions on installing the battery assembly, see [Section 5.1, “Installing the ServerRAID M5000 Series Battery Assembly on a Controller.”](#)





**CAUTION:**

The battery is a lithium ion battery and can present a fire or chemical burn hazard if mistreated. Do not disassemble, heat above 100 °C (212 °F), or incinerate. To avoid possible explosion, do not burn. Keep away from children. Exchange only with the IBM-approved part. Recycle or discard the battery as instructed by local regulations. In the United States, IBM has a process for the collection of this battery. For information, call 1-800-426-4333. Have the IBM part number for the battery unit available when you call. (C007)

---

## 6.3 Transferring Cached Data from a Failed Controller

If you are using the ServeRAID M5014 or ServeRAID M5015 controller with a ServeRAID M5000 Series Battery Assembly, and if the controller fails when there is data in the cache that has not been written to disk, you can save the cached data. To do so, remove the battery assembly from the failed controller and install it on a new controller. To save the data, the following conditions must be met:

- The new controller on which you install the BBU must be the same model as the failed controller
- The replacement controller must have a *cleared configuration*
- The new controller must be connected to the same drives that the failed controller was connected to

Follow these steps to use the iBBU to transfer cached data from a failed controller to a new controller:

**Attention:** Be sure to ground yourself before you touch the controller and the BBU.

1. Shut down the computer, turn off the power, and unplug the power cords.
2. Remove the cover from the computer according to the instructions in the system user's manual so that you can access the controller.
3. Ground yourself before you touch the controller.

4. Unplug all cables from the controller, remove the screw attaching the bracket to the computer case, and carefully remove the failed controller from the slot.
5. Remove the battery assembly from the failed controller.
6. Install the battery assembly on the replacement controller.

**Note:** See [Section 5.1, “Installing the ServerRAID M5000 Series Battery Assembly on a Controller”](#) for instructions on how to install the ServeRAID M5000 Series Battery Assembly on your controller and install the controller in a system.

7. Install the replacement controller in the computer and connect it to the drives.
8. Replace the computer cover and reconnect the power cords. Turn on the power to the computer.

The replacement controller will then read the disk configuration into NVRAM and flush the cached data to the logical drives.

---

## 6.4 Resolving a Configuration Mismatch

If the replacement controller has a previous configuration, this message displays during the power-on self-test (POST):

```
Unresolved configuration mismatch between disk(s) and NVRAM
on the adapter
```

A configuration mismatch occurs when the configuration data in the NVRAM and the configuration data on the drives are different. To resolve this, update the configuration data in the NVRAM with the data from the physical disk. To update the configuration data, follow these steps:

1. Press CTRL+M when prompted during boot-up to access BIOS CU.
2. Select **Configure->View/Add Configuration**.

This gives you the option to view both the configuration on the NVRAM and on the physical disk.

3. Select the configuration on the drive.
4. Press **ESC**, and select **YES** to update the NVRAM.
5. Press **ESC** to exit, and then reboot the computer.

# Chapter 7

## ServeRAID M5000 Series Battery Assembly Specifications

---

This chapter includes technical information and specifications for the ServeRAID M5000 Series Battery Assembly. The ServeRAID M5000 Series Battery Assembly is pre-installed on the ServeRAID M5015 controller to provide battery-protected backup of cached data, allowing system builders to protect cached data even during the most catastrophic system failures.

**Note:** The ServeRAID M5000 Series Battery Assembly is not pre-installed on the ServeRAID M5014 controller but can be installed, if desired. See [Section 5.1, “Installing the ServerRAID M5000 Series Battery Assembly on a Controller”](#) for installation instructions.

Click on the following links to access detailed battery backup unit (BBU) specifications:

- [Section 7.1, “Intelligent Battery Backup Unit Specifications”](#)
- [Section 7.2, “Battery Life and Data Retention Time”](#)

---

## 7.1 Intelligent Battery Backup Unit Specifications

The following specifications apply to the ServeRAID M5000 Series Battery Assembly:

- **Battery type:** LiON, Li-Poly cell
- **Battery operating ambient temperature:** 10–40° C
- **Humidity (storage and operating):** 20% to 80% non-condensing
- **Battery storage temperature:** Depends on storage time, as follows:
  - < 30 days: 0–50° C
  - 30–90 days: 0–40° C

> 90 days: 0–30° C

**Table 7.1    ServeRAID M5000 Series Battery Assembly Specifications**

	<b>ServeRAID M5000 Series Battery Assembly</b>
<b>Fast Charge Rate</b>	500 mA
<b>Battery Pack</b>	1 cell
<b>Mechanical</b>	2.611" x 2.122"
<b>Battery Capacity</b>	1350 mA
<b>Charge Circuitry Card</b>	Yes
<b>Memory Technology</b>	DDR2 SDRAM (1.8V)
<b>Battery Fast Charge Time</b>	~3 hours
<b>Socket Type</b>	N/A
<b>Module Support</b>	DDR2
<b>Cache Memory Size Supported</b>	128 MB - 512 MB
<b>Memory Bus Speed</b>	800 MHz
<b>Memory Bus Width</b>	Maximum 72 bit
<b>Error Correcting Capability (ECC)</b>	N/A
<b>Auxiliary</b>	Yes

---

## 7.2 Battery Life and Data Retention Time

The configuration utilities display a counter showing the number of times the BBU has been recharged. When you install a new battery assembly, the battery recharge cycle counter for the BBU is automatically set to zero. For instructions on installing the BBU, see [Section 5.1, “Installing the ServerRAID M5000 Series Battery Assembly on a Controller.”](#)

For optimal performance, replace the battery backup unit once a year.

The data retention time shown in [Table 7.2](#) is approximate. They can vary based on a number of factors, including the following:

- Capacity of the battery pack and the battery load
- Ambient temperature

- Battery age and the number of discharge cycles
- Number of DIMMs installed and the number of chips on the DIMMs
- DRAM size

**Table 7.2 Reference Data Retention Times**

<b>Data Retention Times</b>
- 48 hours for 512 Mbytes, using five 64 Mx16 parts DDR2
- 48 hours for 256 Mbytes, using five 32 Mx16 parts DDR2
- 48 hours for 128 Mbytes, using five 16 Mx16 parts DDR2



# Chapter 8

## Installing a ServeRAID M5000 Series Advanced Feature Key

---

The ServeRAID M5000 Series Advanced Feature Key enables support for RAID 6 configurations and self-encrypting disks (SED) on the ServeRAID M5015 SAS/SATA controller.

The ServeRAID M5000 Series Advanced Feature Key mounts directly to the controller using the J1 2-pin connector. [Figure 8.1](#) shows the ServeRAID M5000 Series Advanced Feature Key.

**Figure 8.1 M5000 Series Advanced Feature Key**

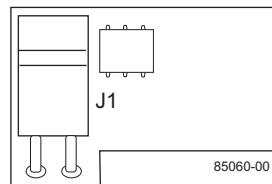

**Note:** It is important to back up any data before you make a change in system configuration. Failure to do this could result in data loss.

---

### 8.1 Installing the ServeRAID M5000 Series Advanced Feature Key on the ServeRAID M5015 SAS/SATA Controller

Perform the following steps to install the ServeRAID M5000 Series Advanced Feature Key directly to the ServeRAID M5015 SAS/SATA controller.

1. Turn off the computer and unplug the power cords from the rear of the power supply.

2. Remove the cover from the computer according to the instructions in the system user's manual so you can access the controller.

**Note:** When handling static sensitive devices, take precautions to avoid damage from static electricity.

3. Ground yourself before you touch the controller or the Advanced Feature Key.
4. Remove the Advanced Feature Key from the package.
5. Hold the Advanced Feature Key so that the J1 connector is up and the connector lines up up with the JT8 header on the controller, as shown in [Figure 8.2](#).
6. Insert the J1 connector into the JT8 header so that the two connectors are firmly joined.

**Figure 8.2** Installing the ServerRAID M5000 Series Advanced Feature Key on the M5015 ServerRAID SAS/SATA Controller

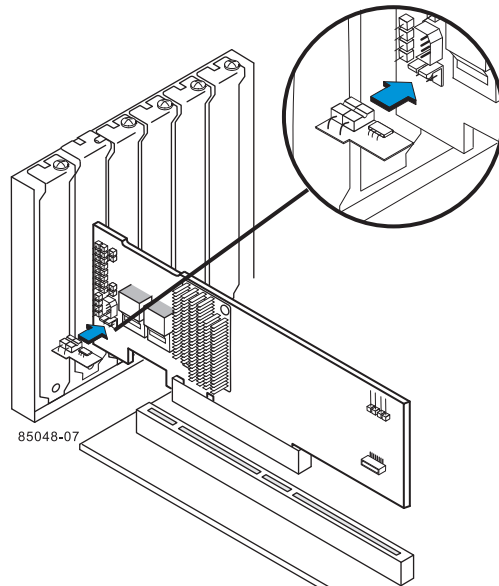



# Appendix A Notices

---

This information was developed for products and services offered in the U.S.A.

IBM® may not offer the products, services, or features discussed in this document in other countries. Consult your local IBM representative for information on the products and services currently available in your area. Any reference to an IBM product, program, or service is not intended to state or imply that only that IBM product, program, or service may be used. Any functionally equivalent product, program, or service that does not infringe any IBM intellectual property right may be used instead. However, it is the user's responsibility to evaluate and verify the operation of any non-IBM product, program, or service.

IBM may have patents or pending patent applications covering subject matter described in this document. The furnishing of this document does not give you any license to these patents. You can send license inquiries, in writing, to:

*IBM Director of Licensing  
IBM Corporation  
North Castle Drive  
Armonk, NY 10504-1785  
U.S.A.*

INTERNATIONAL BUSINESS MACHINES CORPORATION PROVIDES THIS PUBLICATION "AS IS" WITHOUT WARRANTY OF ANY KIND, EITHER EXPRESS OR IMPLIED, INCLUDING, BUT NOT LIMITED TO, THE IMPLIED WARRANTIES OF NON-INFRINGEMENT, MERCHANTABILITY OR FITNESS FOR A PARTICULAR PURPOSE. Some states do not allow disclaimer of express or implied warranties in certain transactions, therefore, this statement may not apply to you.

This information could include technical inaccuracies or typographical errors. Changes are periodically made to the information herein; these changes will be incorporated in new editions of the publication. IBM may make improvements and/or changes in the product(s) and/or the program(s) described in this publication at any time without notice.

Any references in this information to non-IBM Web sites are provided for convenience only and do not in any manner serve as an endorsement of those Web sites. The materials at those Web sites are not part of the materials for this IBM product, and use of those Web sites is at your own risk.

IBM may use or distribute any of the information you supply in any way it believes appropriate without incurring any obligation to you.

---

## A.1 Trademarks

The following terms are trademarks of International Business Machines Corporation in the United States, other countries, or both:

IBM	ServeRAID	System x
IBM (logo)	ServerProven	

Intel, Intel Xeon, Itanium, and Pentium are trademarks of Intel Corporation in the United States, other countries, or both.

Microsoft, Windows, and Windows NT are trademarks of Microsoft Corporation in the United States, other countries, or both.

Adobe and PostScript are either registered trademarks or trademarks of Adobe Systems Incorporated in the United States, other countries, or both.

UNIX is a registered trademark of The Open Group in the United States and other countries.

Java and all Java-based trademarks are trademarks of Sun Microsystems, Inc. in the United States, other countries, or both.

Linux is a registered trademark of Linus Torvalds in the United States, other countries, or both.

Red Hat, the Red Hat “Shadow Man” logo, and all Red Hat-based trademarks and logos are trademarks or registered trademarks of Red Hat, Inc., in the United States and other countries.

Other company, product, or service names may be trademarks or service marks of others.

---

## A.2 Important Notes

IBM makes no representation or warranties regarding non-IBM products and services that are ServerProven<sup>®</sup>, including but not limited to the implied warranties of merchantability and fitness for a particular purpose. These products are offered and warranted solely by third parties.

IBM makes no representations or warranties with respect to non-IBM products. Support (if any) for the non-IBM products is provided by the third party, not IBM.

Some software might differ from its retail version (if available) and might not include user manuals or all program functionality.



# Appendix B

## Glossary of Terms and Abbreviations

---

<b>active termination</b>	The electrical connection required at each end of the SCSI bus, composed of active voltage regulation and a set of termination resistors.
<b>array</b>	An array of drives combines the storage space on the drives into a single segment of storage space. A hot spare drive does not actively participate in an array.
<b>BIOS</b>	Acronym for Basic Input/Output System. Software that provides basic read/write capability. Usually kept as firmware (ROM-based). The system BIOS on the mainboard of a computer boots and controls the system. The BIOS on your host adapter acts as an extension of the system BIOS.
<b>configuration</b>	Refers to the way a computer is set up, the combined hardware components (computer, monitor, keyboard, and peripheral devices) that make up a computer system, or the software settings that allow the hardware components to communicate with each other.
<b>device driver</b>	A program that allows a microprocessor (through the operating system) to direct the operation of a peripheral device.
<b>domain validation</b>	Domain Validation is a software procedure in which a host queries a device to determine its ability to communicate at the negotiated data rate.
<b>EEPROM</b>	Acronym for Electrically Erasable Programmable Read-Only Memory. It is a memory chip that typically stores configuration information, as it provides stable storage for long periods without electricity and can be reprogrammed. Refer to NVRAM.
<b>external SAS device</b>	A SAS device installed outside the computer cabinet. These devices are connected using specific types of shielded cables.
<b>Fusion-MPT architecture</b>	Fusion-MPT (Message Passing Technology) architecture consists of several main elements: Fusion-MPT firmware, the Fibre Channel and SCSI hardware, and the operating system level drivers that support

these architectures. Fusion-MPT architecture offers a single binary, operating system driver that supports both Fibre Channel and SCSI devices.

<b>host</b>	The computer system in which a storage adapter is installed. It uses the storage adapter to transfer information to and from devices attached to the SCSI bus.
<b>host adapter board</b>	A circuit board or integrated circuit that provides a device connection to the computer system.
<b>hot spare</b>	<p>An idle, powered on, standby drive ready for immediate use in case of disk failure. It does not contain any user data. A hot spare can be dedicated to a single redundant array or it can be part of the global hot-spare pool for all arrays managed by the controller.</p> <p>When a disk fails, the controller firmware automatically replaces and rebuilds the data from the failed drive to the hot spare. Data can be rebuilt only from virtual disks with redundancy (RAID levels 1, 5, 10, and 50; not RAID level 0), and the hot spare must have sufficient capacity.</p>
<b>internal SAS device</b>	A SAS device installed inside the computer cabinet. These devices are connected by using a shielded cable.
<b>main memory</b>	The part of a computer's memory which is directly accessible by the CPU (usually synonymous with RAM).
<b>NVRAM</b>	Acronym for Nonvolatile Random Access Memory. An EEPROM (Electrically Erasable Read-Only Memory chip) that stores configuration information. Refer to EEPROM.
<b>PCI</b>	Acronym for Peripheral Component Interconnect. A high-performance, local bus specification that allows the connection of devices directly to computer memory. The PCI Local Bus allows transparent upgrades from 32-bit data path at 33 MHz to 64-bit data path at 33 MHz, and from 32-bit data path at 66 MHz to 64-bit data path at 66 MHz.
<b>PCI Express</b>	Acronym for Peripheral Component Interconnect Express. A high-performance, local bus specification that allows the connection of devices directly to computer memory. PCI Express is a two-way, serial connection that transfers data on two pairs of point-to-point data lines. PCI Express goes beyond the PCI specification in that it is intended as

a unifying I/O architecture for various systems: desktops, workstations, mobile, server, communications, and embedded devices.

**peripheral devices**

A piece of hardware (such as a video monitor, drive, printer, or CD-ROM) used with a computer and under the control of the computer. SCSI peripherals are controlled through a ServeRAID SAS/SATA controller (host adapter).

**PHY**

The interface required to transmit and receive data packets transferred across the serial bus.

Each PHY can form one side of the physical link in a connection with a PHY on a different SATA device. The physical link contains four wires that form two differential signal pairs. One differential pair transmits signals, while the other differential pair receives signals. Both differential pairs operate simultaneously and allow concurrent data transmission in both the receive and the transmit directions.

**RAID**

Acronym for Redundant Array of Independent Disks (originally Redundant Array of Inexpensive Disks). An array of multiple independent physical disks managed together to yield higher reliability and/or performance exceeding that of a single physical disk. The RAID array appears to the controller as a single storage unit. I/O is expedited because several disks can be accessed simultaneously. Redundant RAID levels (RAID levels 1, 5, 10, and 50) provide data protection.

**RAID levels**

A set of techniques applied to disk groups to deliver higher data availability, and/or performance characteristics to host environments. Each virtual disk must have a RAID level assigned to it.

**SAS**

Acronym for Serial Attached SCSI. A serial, point-to-point, enterprise-level device interface that leverages the proven SCSI protocol set. The SAS interface provides improved performance, simplified cabling, smaller connections, lower pin count, and lower power requirements when compared to parallel SCSI. The SAS controller leverages a common electrical and physical connection interface that is compatible with Serial ATA.

The ServeRAID SAS/SATA controller supports the SAS protocol as described in the *Serial Attached SCSI Standard, version 2.0*. The controller also supports the Serial ATA II (SATA II) protocol defined by the *Serial ATA Specification, Version 1.0a*, and the *Serial ATAII*;

*Extension to the Serial ATA Specification, Version 1.1.* SATA II is an extension to SATA 1.0a.

The ServeRAID M5015 SAS/SATA controller is a versatile controller that provides the backbone of both server and high-end workstation environments. Each port on the RAID controller supports SAS devices and/or SATA II devices.

- SAS device** Any device that conforms to the SAS standard and is attached to the SAS bus by a SAS cable. This includes SAS storage adapters (host adapters) and SAS peripherals.
- SATA** Acronym for Serial Advanced Technology Attachment. A physical storage interface standard, SATA is a serial link that provides point-to-point connections between devices. The thinner serial cables allow for better airflow within the system and permit smaller chassis designs.
- SMP** Acronym for Serial Management Protocol. SMP enables communicates topology management information directly with an attached SAS expander device. Each PHY on the controller can function as an SMP initiator.
- SSD** Acronym for Solid State Devices. A Solid State Device uses solid-state memory to store data. They have no moving parts and are faster and more reliable than hard disk drives (HDDs).
- SSP** Acronym for Serial SCSI Protocol. SSP enables communication with other SAS devices. Each PHY on the SAS controller can function as an SSP initiator or SSP target.
- STP** Acronym for Serial Tunneling Protocol. STP enables communication with a SATA II device through an attached expander. Each PHY on the SAS controller can function as an STP initiator.
- stripe size** The total disk space consumed by a stripe not including a parity disk. For example, consider a stripe that contains 64 Kbytes of disk space and has 16 Kbytes of data residing on each disk in the stripe. In this case, the stripe size is 64 Kbytes and the stripe element size is 16 Kbytes. The stripe depth is four (four physical disks in the stripe). You can specify stripe sizes of 8 Kbytes, 16 Kbytes, 32 Kbytes, 64 Kbytes, or 128 Kbytes for each virtual disk. A larger stripe size produces improved read performance, especially if most of the reads are sequential. For mostly random reads, select a smaller stripe size.



**striping**

Disk striping writes data across two or more disks. Each stripe spans two or more disks but consumes only a portion of each disk. Each disk, therefore, may have several stripes. The amount of space consumed by a stripe is the same on each disk included in the stripe. The portion of a stripe that resides on a single disk is a stripe element. Striping by itself does not provide data redundancy; striping in combination with parity provides data redundancy.





